



LSIS Electric Products

ACB / MCCB / MCB / MC&TOR / Mini-MS / MMS / EMPR / VCB



Susol series

- 85, 100 and 130kA short circuit current with instantaneous at 508V
- High functional digital trip relays
- UL approved



Molded Case Circuit Breakers

Susol series

- 2, 3 pole series up to 1200AF
- UL approved

Miniature circuit breakers

- UL 489 R-Series
- UL 1077 R-Series



Metasol series

- 3 and 4 pole series up to 2100AF Mini-contactors available
- AC/DC common use coil from 150AF to 800AF
- Thermal (Bimetallic) and electronic type overload relays are available
- UL approved

Mini contactors

Manual motor starters



Electronic motor protection relays (Electronic type overload relays)

- Various connection & mount
- Reliability by real-time data processing and high precision.
- Wide current setting range & Various protection functions
- Inverse or definite time mode
- Display the causes of the fault by LED
- Ampere meter, Load rate Display type
- Standard, Ground fault and short circuit protection type
- Unit or Extension in one body by cable option
- CE marked and UL approved type

Vacuum Circuit Breakers

Susol series



Air circuit breakers

Ratings for UL Listed/ANSI Certified Susol UA Circuit Breakers



		TYPE		
		AF		
Rated current (I _n max)	(A)		at 40°C	
Rated current	(A)		at 40°C	
Rated Maximum Voltage	(V)			
Frequency	(Hz)			
Number of poles	(P)			
Type of Trip relay (Electronic trip device)				
Rated short circuit current (kA)		With instantaneous	AC 635V	
(Sym.)			508V	
UL 1066			254V	
ANSI C37.13		Without instantaneous	AC 635V	
			508V	
			254V	
Rated short Time current	(kA)			
Operating time (t)	(ms)	Maximum total breaking time		
		Maximum closing time		
Life cycle	ACB	Mechanical	Without maintenance	
			With maintenance	
		Electrical	Without maintenance	
			With maintenance	
Weight	lb (kg)	Drawout type	Main Body	3P
			with Cradle	4P
			Only Cradle	3P
			4P	
		Fixed type	Motor charging type	3P
				4P
External dimension	Draw-out type	Inch (mm)	H×W×D	3P
				4P
	Fixed type	Inch (mm)	H×W×D	3P
				4P
Enclosure dimension		Inch (mm)	H×W×D	3P
				4P



<i>Susol</i>	
UAS- □□D	
08	16
800	1600
	800
400	1000
600	1200
630	1250
800	1600
254V / 508V / 635V	
50/60	
3P / 4P	
N, A, P, S (4 type)	
	65
	85
	85
	65
	65
	65
	65
	50ms
	80ms
	12,500
	2,800
	154 (70)
	187 (85)
	71 (32)
	84 (38)
	77 (35)
	99 (45)
	16.93 × 13.15 × 16.02
	(430 × 334 × 407)
	16.93 × 16.5 × 16.02
	(430 × 419 × 407)
	11.81 × 11.81 × 11.61
	(300 × 300 × 295)
	11.81 × 15.16 × 11.61
	(300 × 385 × 295)
	19.69 × 15.75 × 13.39
	(500 × 400 × 340)
	19.69 × 19.69 × 13.39
	(500 × 500 × 340)



Susol				
UAH- □□E				
08	16	20	25	32
800	1600	2000	2500	3200
400	800	1000	1200	1600
600	1000	1200	1250	2000
630	1200	1250	1600	2500
800	1250	1600	2000	3000
	1600	2000	2500	3200
254V / 508V / 635V				
50/60				
3P / 4P				
N, A, P, S (4 type)				
85				
100				
100				
85				
85				
85				
85				
85				
50ms				
80ms				
12,500			5,000	
2,800			1,000	
214 (97)		245 (111)		326 (148)
269 (122)		309 (140)		414 (188)
99 (45)		123 (56)		205 (93)
121 (55)		152 (69)		256 (116)
101 (46)		110 (50)		196 (89)
126 (57)		137 (62)		249 (113)
16.93 × 16.22 × 16.02 (430 × 412 × 407)				
16.93 × 20.75 × 16.02 (430 × 527 × 407)				
11.81 × 14.88 × 11.61 (300 × 378 × 295)				
11.81 × 19.41 × 11.61 (300 × 493 × 295)				
19.69 × 19.69 × 13.39 (500 × 500 × 340)				
19.69 × 24.21 × 13.39 (500 × 615 × 340)				

Susol		
UAH- □□G		
32	40	50
3200	4000	5000
1600	2000	2500
2000	2500	3000
2500	3000	3200
3000	3200	3600
3200	3600	4000
	4000	5000
254V / 508V / 635V		
50/60		
3P / 4P		
N, A, P, S (4 type)		
100		
130		
130		
100		
100		
100		
100		
100		
50ms		
90ms		
5,000		
1,000		
489 (222)		
626 (284)		
276 (125)		
355 (161)		
227 (103)		
287 (130)		
18.11 × 30.91 × 16.02 (460 × 785 × 407)		
18.11 × 39.96 × 16.02 (460 × 1015 × 407)		
11.81 × 29.57 × 11.61 (300 × 751 × 295)		
11.81 × 38.62 × 11.61 (300 × 981 × 295)		
31.5 × 32.48 × 13.39 (800 × 825 × 340)		
31.5 × 41.54 × 13.39 (800 × 1055 × 340)		

Trip relay(OCR)

The trip relay of Susol ACB provides the additional protection functions for voltage, frequency, unbalance, and others in addition to main protection functions for over current, short-circuit, ground fault. It supports the advanced measurement functions for voltage, current, power, electric energy, harmonics, communication function, and others.





Analog trip function interlocked with mechanism enhanced a durability of devices as well as the breaking capacity of ACB.

Zone selective interlocking function makes the protective coordination more simple and thermal memory can be applied to various loads.



Air circuit breakers

Trip relay types

Classification	N type	A type	P type	S type
Externals				
Current protection	• L / S / I / G	• L / S / I / G / Thermal • ZSI(Protective coordination)	• L / S / I / G / Thermal(Continuous) • ZSI(Protective coordination)	• P type
Other protection	-	• Earth leakage (Option)	• Earth leakage(Option) • Over/Under current • Over/Under frequency • Unbalance(Voltage/Current) • Reverse power	• P type
Measurement function	-	• Current (R / S / T / N)	• 3 Phase Voltage/Current RMS/Vector • Power(P, Q, S), PF(3-Phase) • Energy(Positive/Negative) • Frequency, Demand	• 3 Phase Voltage/Current RMS/Vector • Power(P, Q, S), PF(3-Phase) • Energy(Positive/Negative) • Frequency, Demand • Voltage/Current harmonics (1st-63th) • 3 Phase Waveforms • THD, TDD, K-Factor
Fine adjustment	-	-	• Fine adjustment for long/short time delay/instantaneous/ ground	• P type
Pre Trip Alarm	-	-	• Overload protection relays : DO (Alarm) (Ground fault is not available when using Pre trip alarm)	• P type
Digital Output	-	• 3DO (Fixed) • L, S/I, G Alarm	• 3DO (Programmable) • Trip, Alarm, General	• P type
IDMTL setting	-	-	• Compliance with IEC60255-3 SIT, VIT, EIT, DT	• P type
Communication	-	• Modbus/RS-485 • Profibus-DP	• Modbus / RS-485 • Profibus-DP	• Modbus / RS-485 • Profibus-DP
Power supply	• Self Power - Power source works over 20% of load current.	• Self Power - Power source works over 20% of load current. - External power source are required for comm. • AC/DC 100~250V • DC 24~60V	• AC/DC 100~250V • DC 24~60V	• AC/DC 100~250V • DC 24~60V
RTC timer	• Available	• Available	• Available	• Available
LED for trip info.	• Long time delay • Short time delay/Instantaneous • Ground fault	• N type	• N type	• N type
Fault recording	-	• 10 records (Fault/Current/Date and Time)	• 256 records (Fault/Current/Date and Time)	• 256 records • Last fault wave recording (3 Phase)
Event recording	-	-	• 256 records(Content, Status, Date)	• P type
Operating button	• Reset button	• Reset, Menu Up/Down, Left/Right, Enter	• A type	• A type

Basic protection function(L / S / I / G) is still under normal operation without control power.

Air circuit breakers

Numbering system

Breaker and Accessories

UAS	—	10	D	3	—	10	A		
Frame Type	Frame Size	Phasing		Poles		Sensor Rating		Mounting and Terminal	
	08 800AF 16 1600AF	D	3/4P Standard	3	3P	04~08	400A~800A	Mounting	
			RST(N)	4	4P	08~16	800A~1600A	A	Drawout
		W	4P Reversed NRST					Fixed	
								H	Horizontal terminals
								V	Vertical terminals
								M	Horizontal for line
									Vertical for load
								N	Vertical for line
									Horizontal for load
								P	Front terminal
								G	Horizontal-con type
								W	Vertical-con type

UAH	—	32	E	3	—	32	
Frame Type	Frame Size	Phasing		Poles		Sensor Rating	
	08 800AF 16 1600AF 20 2000AF 25 2500AF 32 3200AF	E	3/4P Standard	3	3P	04~08	400A~800A
			RST(N)	4	4P	08~16	800A~1600A
		X	4P Reversed NRST			10~20	1000A~2000A
						12~25	1200A~2500A
						16~32	1600A~3200A
	32 3200AF 40 4000AF 50 5000AF	G	3/4P Standard	3	3P	16~32	1600A~3200A
			RST(N)	4	4P	20~40	2000A~4000A
			Z	4P Reversed NRST			25~50

* Terminals for P type must be ordered separately
 * G and W types can be applicable to UAS-08D, UAS-16D only
 * Front terminal is only available for 800~2000A

UAA	—	16	D	3	—	00	
Frame Type	Frame Size	Phasing		Poles		Sensor Rating	
	08 800AF 16 1600AF 20 2000AF 25 2500AF 32 3200AF 40 4000AF 50 5000AF	D	3/4P Standard	3	3P	Not applied	
			RST(N)	4	4P		
		W	4P Reversed NRST				
		E	3/4P Standard				
			RST(N)				
		X	4P Reversed NRST				
		G	3/4P Standard				
			RST(N)				
			Z	4P Reversed NRST			

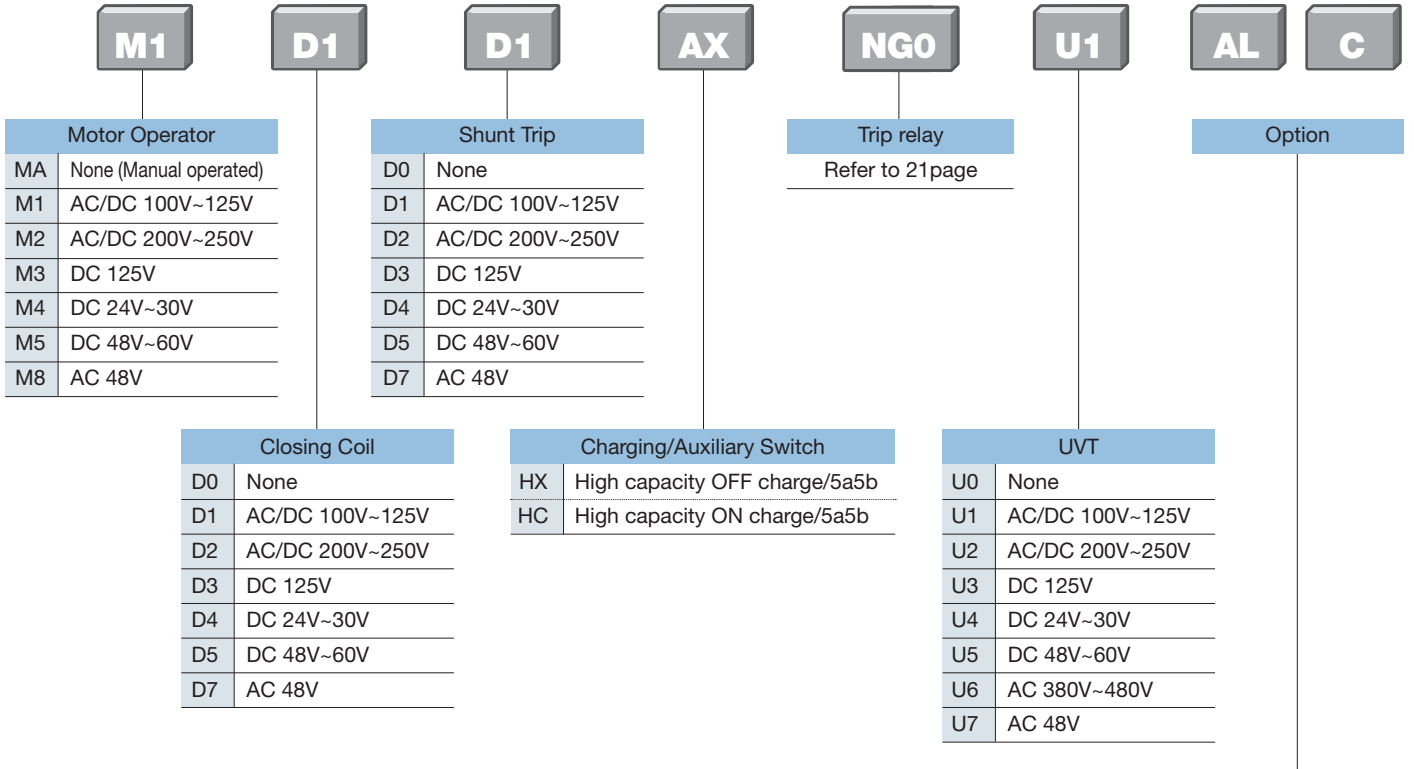

Code	Description	Code	Description	
AL	AL1+MRB	M	MI Mechanical interlock	
A1	AL1+MRB +RES(AC110~130V) *AC only	D	DI or MOC Door Interlock or MOC(Mechanism operated cell switch)	
A2	AL1+AL2 +MRB	K	K1 Key Lock	
A3	AL1+MRB +RES(DC110~125V) *DC only	K2	K2 Key Interlock Set	
A4	AL1+MRB +RES(AC200~250V) *AC only	K3	K3 Key Interlock Double	
A5	AL1+MRB +Auto Reset	R	RCS Ready to Close switch	
A6	AL1+AL2 +MRB +Auto Reset	T	TM Temperature Monitoring	
A7	AL1+MRB +RES(DC110~125V) +Auto Reset *DC only	H1	SHT2 Note 2) AC/DC 100V ~125V, Double Shunt coil	
A8	AL1+MRB +RES(AC200~250V) +Auto Reset *AC only	H2		AC/DC 200V ~250V, Double Shunt coil
A9	AL1+MRB +RES(AC110~130V) +Auto Reset *AC only	H3		DC 125V, Double Shunt coil
C	C COUNTER	H4		DC 24V ~30V, Double Shunt coil
S	CS2 Charge switch communication	H5		DC 48V ~60V, Double Shunt coil
B	B On/Off Button lock	H7		AC 48V, Double Shunt coil

N01	A4 (AL1+MRB +RES(AC200~250V))+C(Counter)+B(ON/OFF Button Lock)+K(Key Lock)+R(Ready to Close switch)+M(Mechanic Interlock)+E(Spring Auto Release)
N02	AL (AL1+MRB)+K(Key Lock(OFF Lock))+R(Ready to Close switch)+D(Door Interlock or MOC)+H1(AC/DC 100V ~ 130V, Double Shunt coil)+E(Spring Auto Release)
N03	C(Counter)+B(ON/OFF Button Lock)+K2(Key Interlock Set)+R(Ready to Close switch)+T(Temperature Monitoring)
N04	A4(AL1+MRB+RES(AC200~250V))+B(ON/OFF Button Lock)+K(Key Lock(OFF Lock))+M(Mechanical Interlock)+T(Temperature Monitoring)
N05	A1(AL1+MRB+RES110~130V)+B(ON/OFF Button Lock)+K(Key Lock(OFF Lock))+R(Ready to Close switch)+M(Mechanical Interlock)+T(Temperature Monitoring)
N06	A2(AL1+AL2+MRB)+C(Counter)+K(Key Lock(OFF Lock))+R(Ready to Close switch)+T(Temperature Monitoring)

Note) * Codes for over 5 optional accessories are composed separately
 **UVT and SHT2 can not be selected together. Select one of two.

Air circuit breakers

Numbering system

Adapter (Cradle)

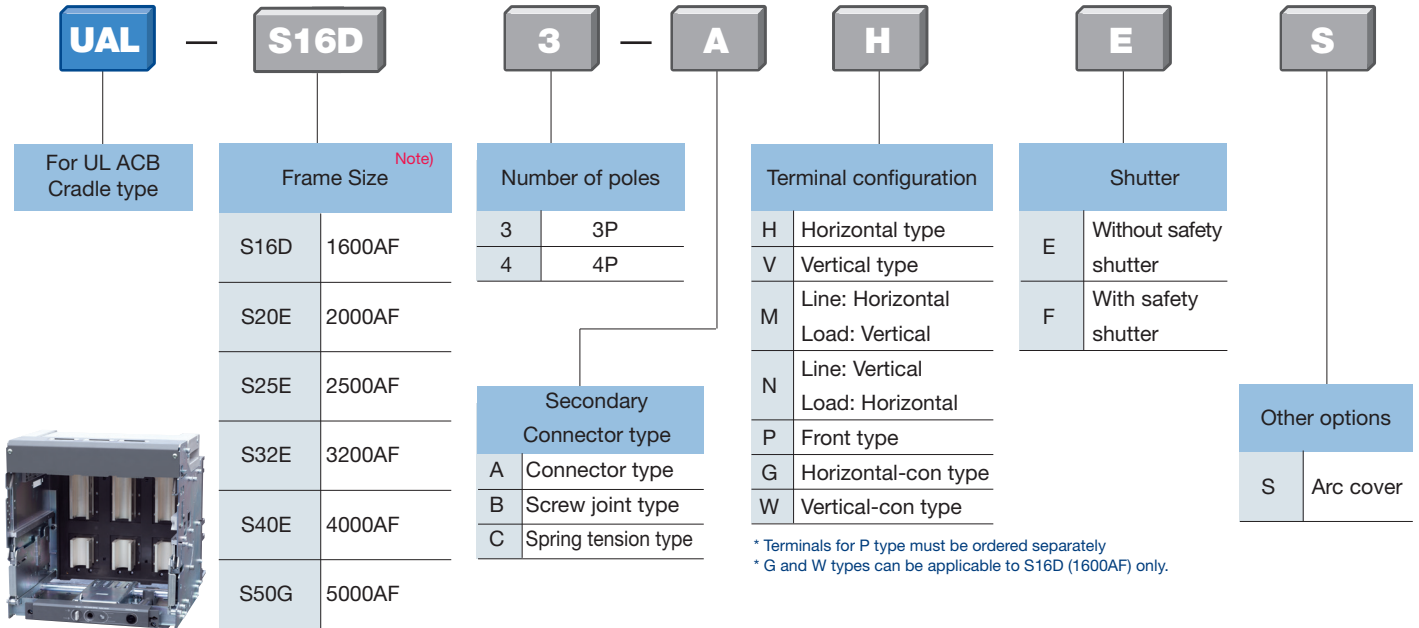

(Note) The corresponding Breaker Adapter

Breaker		Adapter
UAS-08D	UAS-08W	S16D
UAS-16D	UAS-16W	
UAH-08E	UAH-08X	S20E
UAH-16E	UAH-16X	
UAH-20E	UAH-20X	
UAH-25E	UAH-25X	S25E
UAH-32E	UAH-32X	S32E
UAH-32G	UAH-32Z	S50G
UAH-40G	UAH-40Z	
UAH-50G	UAH-50Z	

Trip relay

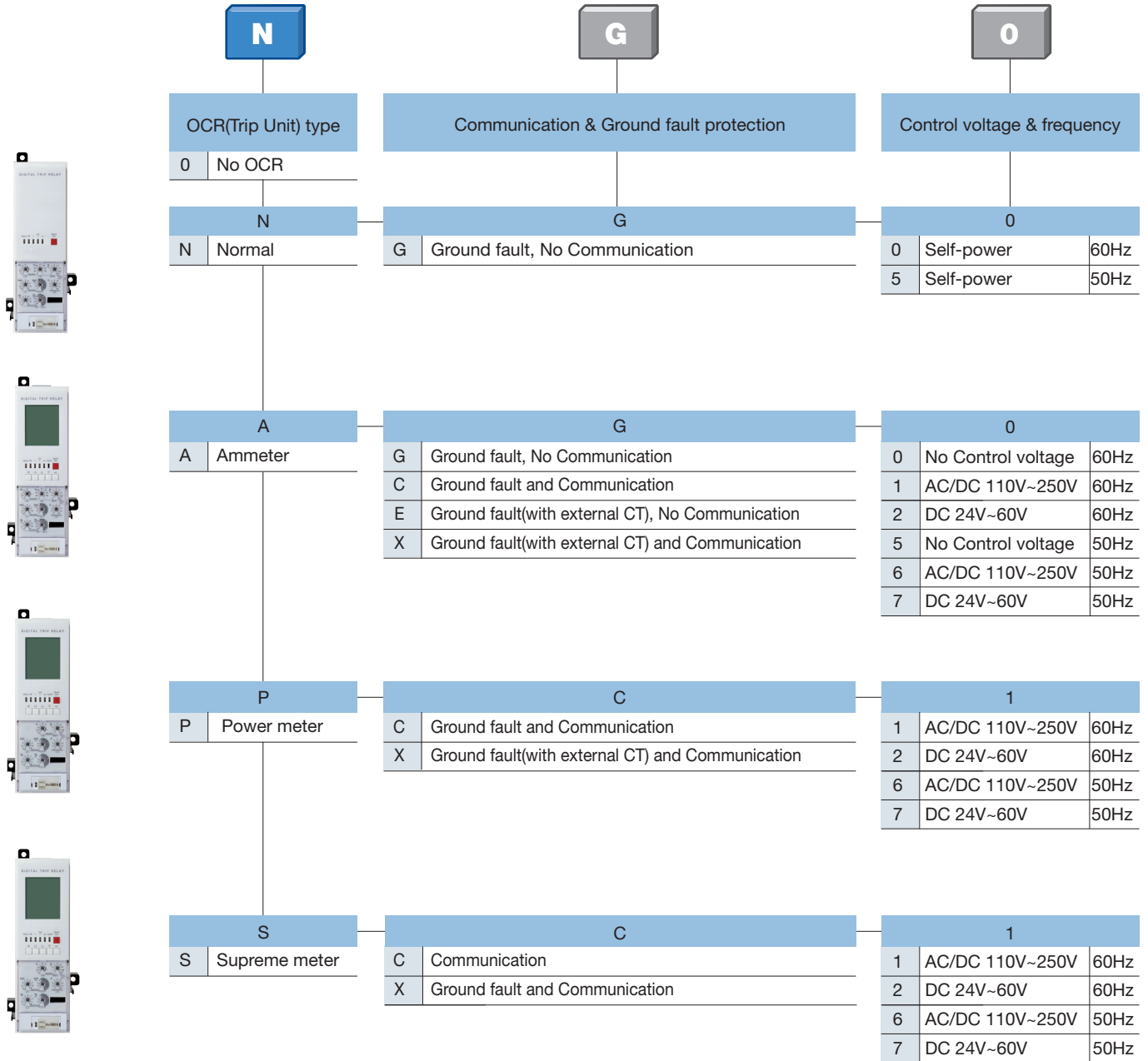

- * Ground fault detection by current vector sum of 4 phase (R,S,T,N)
- * Communication and output contacts for L,S,I,G do not work except OCR LED without control power supply.
- * P and S types require Voltage Module to be ordered separately.
- * LCD in trip unit can be display more than 10% of rated current.
- * Current measuring value display more than 15% of rated current.

Molded case circuit breakers

UTE/UTS 2, 3 pole series up to 1200AF

Maximum
Rated Current
(Amperes)



Frame	
Maximum Rated Current	
Number of Poles	
Breaker Type	
UL489/CSA C22.2/NOM	
Interrupting Capacity (kA rms)	120/240V
AC(50/60HZ)	240V ac
UL, CSA, NOM	480V ac
	600V ac
	600Y/347V ac
UL489 DC	
Interrupting Capacity (kA) DC	250V dc-2P
UL, CSA	500V dc-3P
	600V dc-3P
IEC 60947-2	
Ultimate Breaking Capacity, (kA rms) AC	220/240V
50/60Hz, Icu	380/415V
	480/500V
Service breaking capacity, Ics (%Icu)	
Insulation Voltage, Ui	
Impulse Withstand Voltage, Uimp	
Rated Short-time Withstand Current (Icw)	
Utilization Category	
TRIP UNITS	Amperes
F : Fixed	ATU
A : Adjustable	FMU
T : Thermal	FTU
M : Magnetic	OCR
E : Electronics	
MCP	Amperes
	MCP
MCS	Amperes
	MCS
Unit Mounted	
Mechanical Lugs	
Busbar connectors	
Control Wire Terminal Kit	
Terminal Shields	
Interphase Barriers	
Shunt Trip	
Undervoltage Trip	
Auxiliary Switch	
Alarm Switch	
Flange Cable Handle	
Flange Variable-Depth Mechanism	
Directly-Mounted Rotary Operating Handle	
NEMA-Door-Mounted Operating Mechanisms	
IEC-Door-Mounted Operating Mechanisms	
Mechanical Interlocks	
Handle Padlock Attachment	
Weight(approximate)	2-Pole
lbs.(kg)	3-Pole
Dimensions	poles
Inches(mm)	2-Pole
	3-Pole

UTE100		UTE100		UTS150		
100A		100A		150A		
2		3		2, 3		
E	N	E	N	N	H	L
UTE100		UTE100		UTS150		
50	65	50	65	-	-	-
50	65	50	65	65	100	150
25	35	25	35	35	65	100
-	-	-	-	18	35	50
14	18	14	18	-	-	-
UTE100		UTE100		UTS150		
16	25	16	25	35	50	65
-	-	25	35	-	-	-
-	-	-	-	35	50	65
UTE100		UTE100		UTS150		
50	65	50	65	65	100	150
25	35	25	35	35	65	100
-	-	-	-	18	35	50
100%		100%		100%		
750 Vac		750 Vac		750 Vac		
8 kVac		8 kVac		8 kVac		
-		-		-		
A		A		A		
15-100A		15-100A		40-150A		
-		-		●		
-		●		●		
●		●		●		
-		-		-		
-		-		1.6-60A		
-		-		100-150A		
-		-		●		
100A		100A		150A		
●		●		●		
●		●		●		
●		●		●		
●		●		●		
-		-		-		
●		●		●		
●		●		●		
●		●		●		
●		●		●		
●		●		●		
-		-		-		
●		●		●		
1.64(0.74)		-		3.44(1.56)		
-		2.33(1.06)		3.95(1.79)		
W	H	D		W	H	D
2.01(51)	5.12(130)	3.44(87.5)		4.13(105)	6.46(165)	3.44(87.5)
2.99(76)	5.12(130)	3.44(87.5)		4.13(105)	6.46(165)	3.44(87.5)



UTS250			UTS400			UTS600			UTS800			UTS1200			
250A			400A			600A			800A			1200A			
2, 3			2, 3			2, 3			3			3			
N	H	L	N	H	L	N	H	L	N	H	L	N	H	P	L
UTS250			UTS400			UTS600			UTS800			UTS1200			
-	-	-	-	-	-	-	-	-	-	-	-	-	-	-	-
65	100	150	65	100	150	65	100	150	65	100	150	50	100	65	150
35	65	100	35	65	100	35	65	100	35	65	100	35	65	50	100
18	35	50	18	35	50	18	35	50	18	35	50	18	25	50	35
-	-	-	-	-	-	-	-	-	-	-	-	-	-	-	-
UTS250			UTS400			UTS600			UTS800			UTS1200			
35	50	65	35	50	65	35	50	65	-	-	-	-			
-	-	-	-	-	-	-	-	-	-	-	-	-			
35	50	65	35	50	65	35	50	65	-	-	-	-			
UTS250			UTS400			UTS600			UTS800			UTS1200			
65	100	150	65	100	150	65	100	150	65	100	150	50	100	65	150
35	65	100	35	65	100	35	65	100	35	65	100	35	65	50	100
18	35	50	18	35	50	18	35	50	18	35	50	25	35	50	50
100%			100%			100%			100%			100%			
750 Vac			750 Vac			750 Vac			1000 Vac			1000 Vac			
8 kVac			8 kVac			8 kVac			8 kVac			8 kVac			
-			-			-			18KA			-			
A			A			A			B A			B A B A			
150-250A			250/300/350/400A			500/600A			400/600/630/800A			800/1000/1200A			
●			●			●			-			-			
●			●			●			-			-			
●			●			●			-			-			
-			-			-			●			●			
220A			320A			500A			800A			1200A			
●			●			●			●			●			
250A			400A			600A			800A			1200A			
●			●			●			●			●			
●			●			●			●			●			
●			●			●			●			●			
●			●			●			●			●			
-			-			-			-			-			
●			●			●			●			●			
●			●			●			●			●			
●			●			●			●			●			
●			●			●			●			●			
●			●			●			●			●			
●			●			●			●			●			
●			●			●			●			●			
●			●			●			●			●			
●			●			●			●			●			
●			●			●			●			●			
●			●			●			●			●			
●			●			●			●			●			
3.88(1.76)			12.02(5.45)			13.45(6.10)			-			-			
4.49(2.04)			13.89(6.30)			15.79(7.16)			31.35(14.22)			40.28(18.27)			
W	H	D	W	H	D	W	H	D	W	H	D	W	H	D	
4.13(105)	7.48(190)	3.44(87.5)	5.51(140)	11.5(292)	4.33(110)	5.51(140)	13.39(340)	4.33(110)	8.5(216)	13(330)	6(152.5)	8.5(216)	16.26(413)	6(152.5)	
4.13(105)	7.48(190)	3.44(87.5)	5.51(140)	11.5(292)	4.33(110)	5.51(140)	13.39(340)	4.33(110)	8.27(210)	13(330)	6(152.5)	8.27(210)	16.26(413)	6(152.5)	

Molded case circuit breakers

Numbering system

UL MCCB 100~600AF

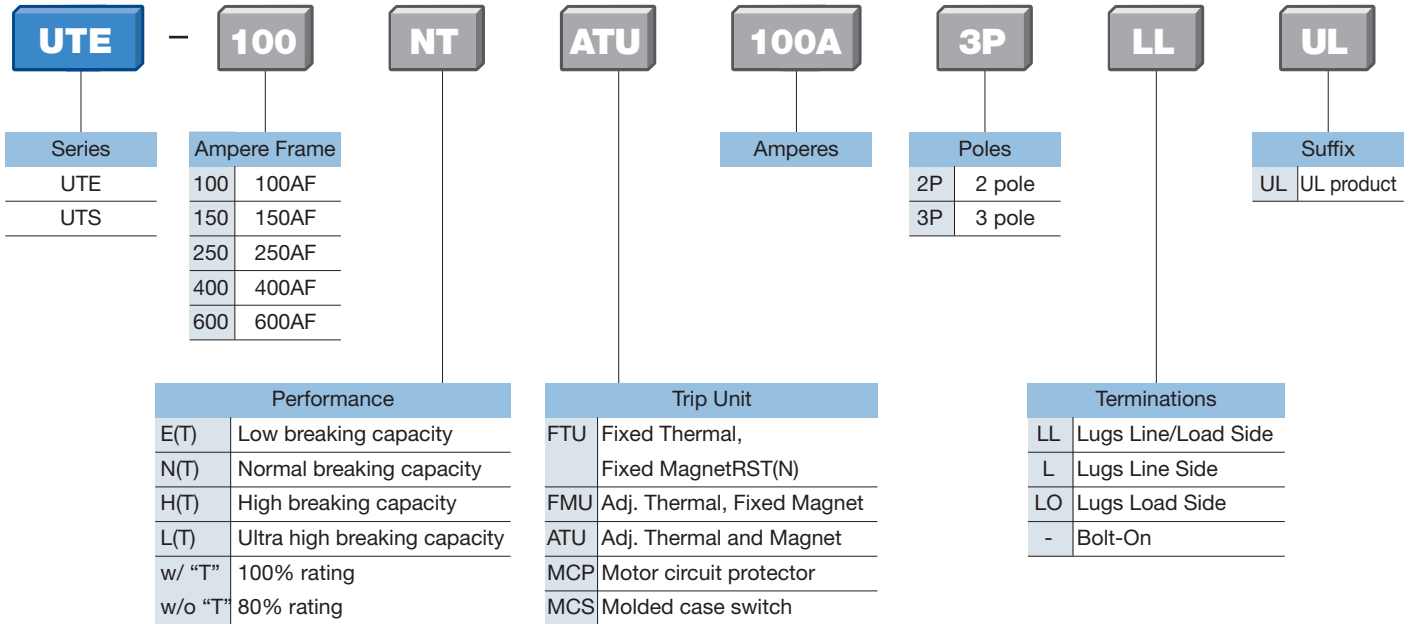

UL MCCB 800~1200AF

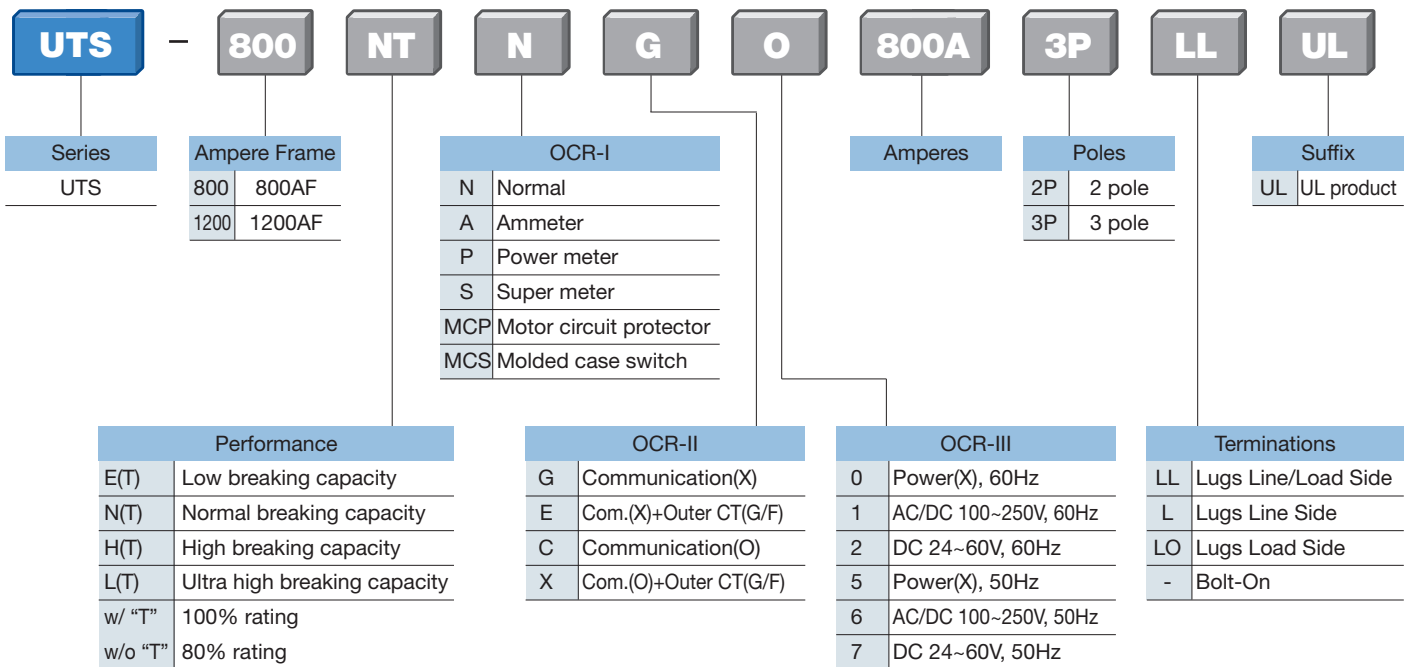

Miniature circuit breakers

UL MCB



BK63H-UL 1P

BK63H-UL 2P

BK63H-UL 3P

BK63H-UL 4P

Ratings

Performance	UL489 MCB *	UL1077 MCB
Standard	UL489, UL486E(Lug)	UL 1077
Protection	Overload, Short circuit	Overload, Short circuit
Rated current	1, 2, 3, 4, 6, 10, 16, 20, 25, 32, 40, 50, 63A	1, 2, 3, 4, 6, 10, 16, 20, 25, 32, 40, 50, 63A
Number of poles	1P, 2P, 3P	1P, 2P, 3P, 4P
Rated short circuit capacity	1P: 10kA @120/240VAC, 1~63A 2~3P: 10kA @240VAC, 1~63A 1P: 10kA @277VAC, 1~25A 2~3P: 10kA @480Y/277VAC, 1~25A	1P: 10kA @120/240VAC 6kA @277VAC 2~4P: 10kA @120/240VAC 6kA @480Y/277VAC
Rated frequency	50/60 Hz	50/60 Hz
Reference temperature	40°C	40°C
Normal ambient temperature	-5 ~ 40°C	-5 ~ 40°C
Tripping curve	B, C, D Curve	B, C, D Curve
Trip type	Thermal Magnetic	Thermal Magnetic
Type of terminals	Terminal with stirrup(indirect pressure)	Terminal with stirrup(indirect pressure)
Terminal size acceptability - Min/Max	14 / 4AWG	14 / 4AWG
Tightening Torque	3.9 Nm (35 lbf-in)	2Nm (17.5 lbf-in)
Installation	Mounting on 35mm Din rail	Mounting on 35mm Din rail
Dimension of specimen (W×H×D)	18×105×66 (1P)	18×81×66 (1P)
Protection degree	IP20	IP20
Accessory	AX-HU, AL-HU, SHT-HU, UVT-HU	AX-H, AL-H, SHT-H, UVT-H
Relative humidity	45~85%RH	45~85%RH
Electrical Endurance	6,000	6,000
Maximum switching frequency (time/h)	360/h	360/h
Approvals	UL	UL, CB, CCC

* Will be available within 2015

Miniature circuit breakers

Numbering system/Operating curve

UL489 MCB

BK	63H	U	1P	B	63A	10kA	240VAC
Series MCB	AF 63	Standard U UL489	Poles 1P 2P 3P 4P	Type B-Type C-Type D-Type	A 1, 2, 3, 4, 6, 10, 16, 20, 25, 32, 40, 50, 63	kA 10	Rated voltage 120/240VAC 240VAC 277VAC 480Y/277VAC

UL1077 MCB

BK	63H	U	1P	B	63A	10kA	240VAC
Series MCB	AF 63	Standard U UL1077	Poles 1P 2P 3P 4P	Type B-Type C-Type D-Type	A 1, 2, 3, 4, 6, 10, 16, 20, 25, 32, 40, 50, 63	kA 6 10	Rated voltage 120/240VAC 240VAC 277VAC 480Y/277VAC

Operating curve

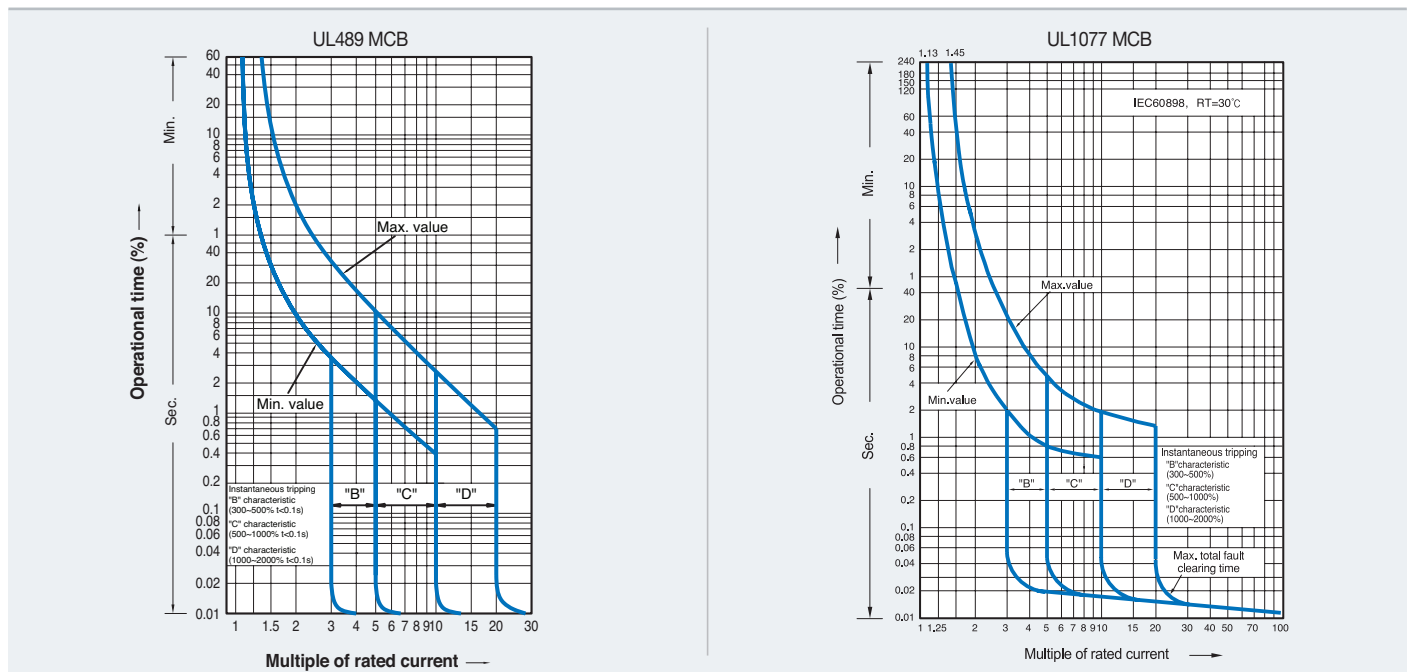

Dimensions

UL489 MCB

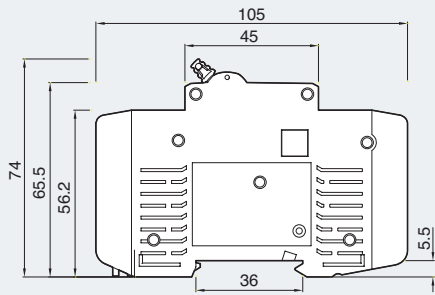
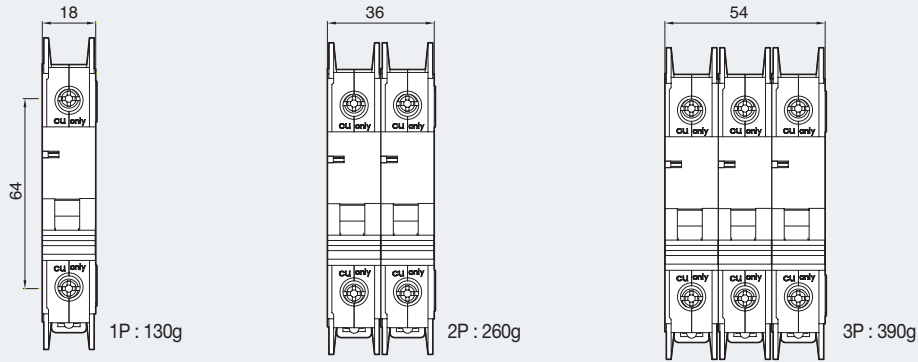

AX-HU/AL-HU

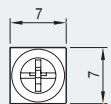
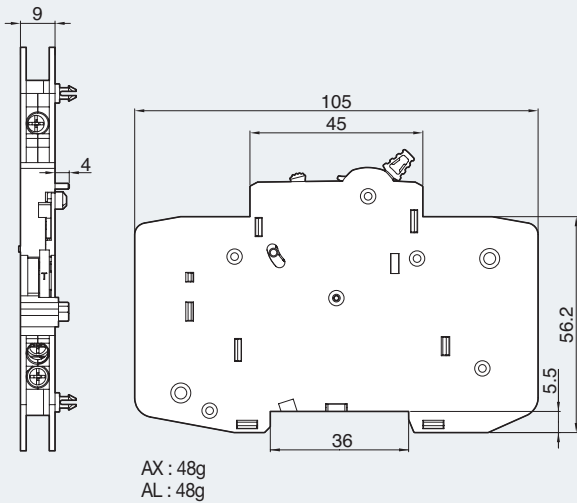

SHT-HU/UVT-HU

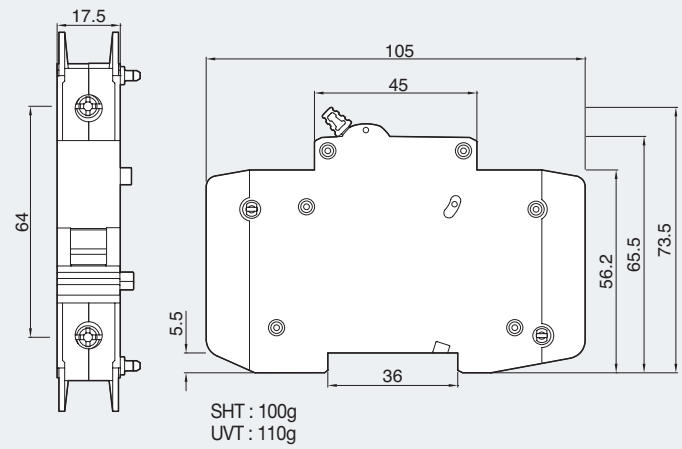

Miniature circuit breakers

Dimensions

UL1077 MCB

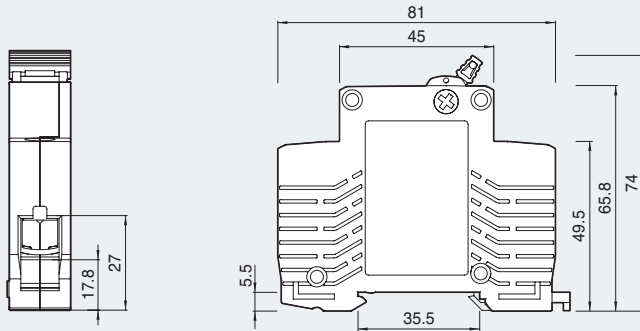
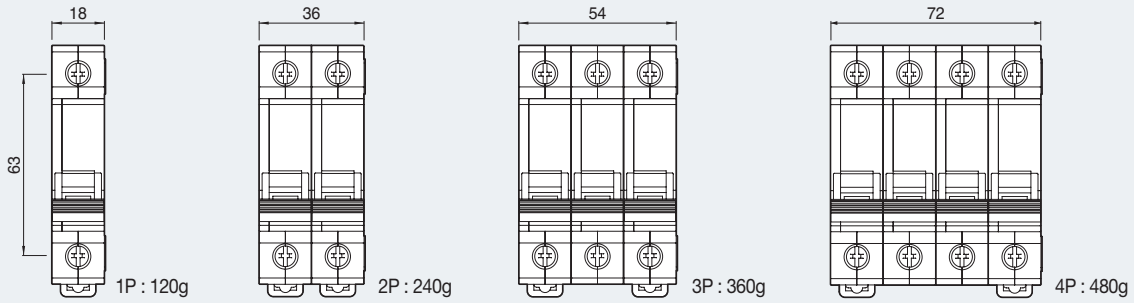

AX-H/AL-H

SHT-H/UVT-H

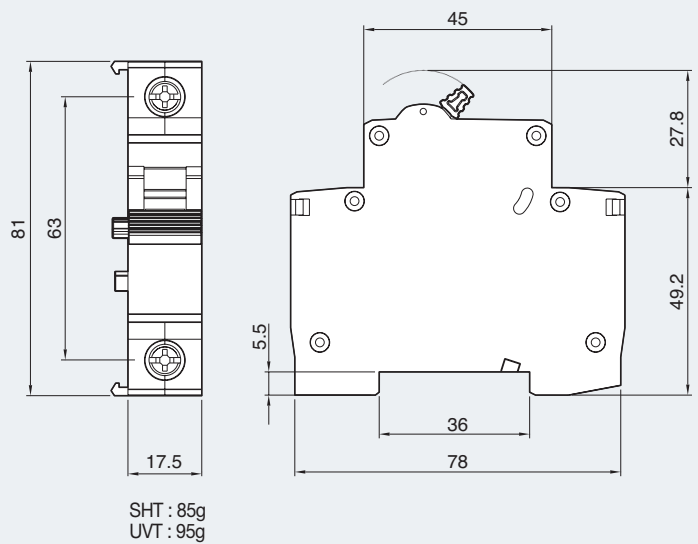
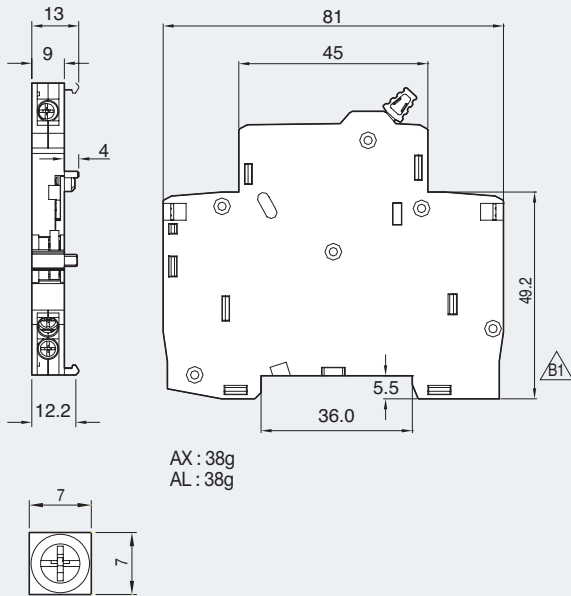

Accessory

Accessory connecting

• Both Aux. contacts and Tripping devices

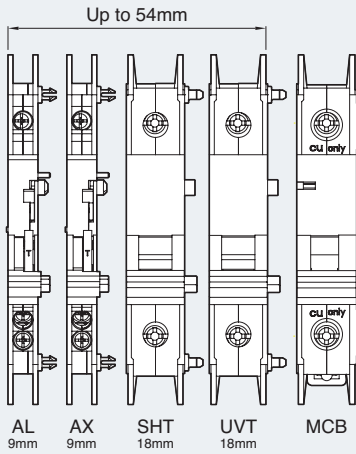

• Aux. contacts

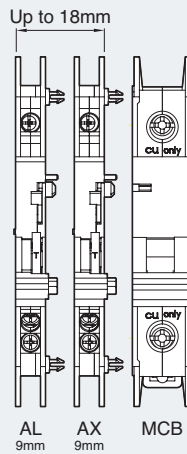

• Tripping devices

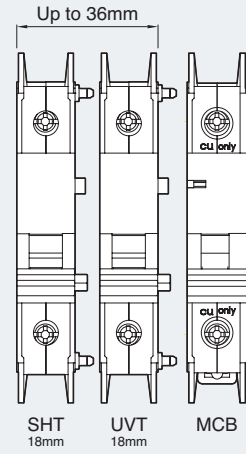

Accessory Numbering system

AX

H

UL1077

Type	
AX	Auxiliary switch
AL	Alarm switch
SHUT	Shunt trip device
SVT	Under voltage trip device

UL MCB	
H (UL1077)	BK63H
HU (UL489)	BK63HU

Standard	
UL1077	UL1077
UL489	UL489

Contactors & Overload relays

Metasol MC 3P 18 to 150A

MC type Magnetic Contactors



Frame size			
Type	screws clamp terminals		
Number of poles	3pole		
Rated operational voltage, Ue	690V		
Rated insulation voltage, Ui	690V		
Rated frequency	50/60Hz		
Rated impulse withstand voltage, Uimp	6kV		
Maximum operating rate in operating cycles per hour(AC3)	1800 operations per hour		
Durability	Mechanical	15 mil. operations	
	Electrical	2.5 mil. operations	
UL rating (50/60Hz)	Continuous current	A	
	Single phase	110~120V	HP
		220~240V	HP
	Three phase	200~208V	HP
		220~240V	HP
		440~480V	HP
	550~600V	HP	
	NEMA size		
Size and weight	AC control	Weight	kg
		Size	inch
		W×H×D	(mm)
	DC control	Weight	kg
		Size	inch
		W×H×D	(mm)
Auxiliary(standard)			
Auxiliary	Side mount		
	Front mount		



18AF			
MC-6a	MC-9a	MC-12a	MC-18a
●	●	●	●
3pole			
690V			
690V			
50/60Hz			
6kV			
1800 operations per hour			
15 mil. operations			
2.5 mil. operations			
25	25	25	32
0.5	0.5	0.75	1
1.5	1.5	2	3
2	2	3	5
3	3	5	7.5
5	5	7.5	10
7.5	7.5	10	15
00	00	0	1
0.33			
1.77×2.89×3.17			
(45×73.5×80.4)			
0.5			
1.77×2.89×4.36			
(45×73.5×110.7)			
1NO or 1NC			
UA-1			
UA-2, UA-4			

22AF			
MC-9b	MC-12b	MC-18b	MC-22b*
●	●	●	●
3pole			
690V			
690V			
50/60Hz			
6kV			
1800 operations per hour			
15 mil. operations			
2.5 mil. operations			
25	25	40	40
0.5	0.75	1	2
1.5	2	3	3
2	3	5	7.5
3	5	7.5	10
5	7.5	10	15
7.5	10	15	20
00	00	1	
0.34			
1.77×2.89×3.44			
(45×73.5×87.4)			
0.51			
1.77×2.89×4.63			
(45×73.5×117.7)			
1NO1NC			
UA-1			
UA-2, UA-4			

Note) Minimum conduct current of Auxiliary contactor is DC 17V 5mA.

MT type Thermal Overload Relays



Type	Screws clamp terminals		
Rated operational voltage, Ue	690V		
Rated insulation voltage, Ui	690V		
Rated impulse withstand voltage, Uimp	6kV		
Trip class	10A, 20		
Setting range	0.1~18A		
Size and weight	Weight	kg	
	Size	inch	
	W×H×D	(mm)	



MT-12/□	
●	
690V	
690V	
6kV	
10A, 20	
0.1~18A	
0.1	
1.77×2.88×2.51	
(45×73.2×63.7)	

MT-32/□	
●	
690V	
690V	
6kV	
10A, 20	
0.1~40A	
0.17	
1.77×2.95×3.54	
(45×75×90)	

* The safety cover of magnetic contactor and thermal overload relay is optional.



40AF	
MC-32a	MC-40a
●	●
3pole	
690V	
1000V	
50/60Hz	
8kV	
1800 operations per hour	
12 mil. operations	
2 mil. operations	
50	60
2	3
5	7.5
7.5	15
10	15
20	30
25	30
1P	2
0.4	
1.77×3.27×3.54 (45×83×90)	
0.6	
1.77×3.27×4.61 (45×83×117.1)	
UA-1	
UA-2, UA-4	

65AF	
MC-50a	MC-65a
●	●
3pole	
690V	
1000V	
50/60Hz	
8kV	
1800 operations per hour	
12 mil. operations	
2 mil. operations	
70	100
3	5
10	15
20	25
25	30
40	50
50	60
0.9	
2.17×4.17×4.69 (55×106×119)	
1.2	
2.17×4.17×5.76 (55×106×146.4)	
UA-1	
UA-2, UA-4	

100AF		
MC-75a	MC-85a	MC-100a
●	●	●
3pole		
690V		
1000V		
50/60Hz		
8kV		
1800 operations per hour		
12 mil. operations		
2 mil. operations		
110	135	160
5	7.5	10
15	15	20
25	30	30
30	40	40
50	60	75
60	75	75
1.6		
2.76×5.51×5.35 (70×140×135.8)		
2.6		
2.76×5.51×6.78 (70×140×172.3)		
UA-1		
UA-2, UA-4		

150AF	
MC-130a	MC-150a
●	●
3pole	
690V	
1000V	
50/60Hz	
8kV	
1200 operations per hour	
5 mil. operations	
1 mil. operations	
160	210
10	15
20	25
40	40
40	50
75	100
75	75
2.4	
3.74×6.22×5.20 (95×158×132)	
2.3	
3.74×6.22×5.20 (95×158×132)	
UA-1	
UA-2, UA-4	



MT-32/□
●
690V
690V
6kV
10A, 20
0.1~40A
0.17
1.77×2.95×3.54 (45×75×90)

MT-32/□
●
690V
690V
6kV
10A, 20
0.1~40A
0.17
1.77×2.95×3.54 (45×75×90)

MT-95/□
●
690V
690V
6kV
10A, 20
7~100A
0.48/0.5
2.76×3.82×4.33 (70×97×110)

MT-32/□
●
690V
690V
6kV
10A, 20
0.1~40A
0.17
1.77×2.95×3.54 (45×75×90)

Contactors & Overload relays

Metasol MC 3P 225 to 2100A

MC type Magnetic Contactors



Frame size			
Type	screws clamp terminals		
Number of poles	3pole		
Rated operational voltage, Ue	690V		
Rated insulation voltage, Ui	1000V		
Rated frequency	50/60Hz		
Rated impulse withstand voltage, Uimp	8kV		
Maximum operating rate in operating cycles per hour(AC3)	1200 operations per hour		
Durability	Mechanical	5 mil. operations	
	Electrical	1 mil. operations	
UL rating (50/60Hz)	Continuous current	A	
	Single phase	110~120V	HP
		220~240V	HP
		200~208V	HP
	Three phase	220~240V	HP
		440~480V	HP
		550~600V	HP
NEMA size			
Size and weight	AC control	Weight	kg
	DC control	Size	inch
		W×H×D	(mm)
	DC control	Weight	kg
Size		inch	
W×H×D (mm)			
Auxiliary(standard)			
Auxiliary	Side mount		
	Front mount		



225AF	
MC-185a	MC-225a
●	●
3pole	
690V	
1000V	
50/60Hz	
8kV	
1200 operations per hour	
5 mil. operations	
1 mil. operations	
230	275
15	15
30	40
60	60
60	75
125	150
125	150
5.4	
5.43×7.99×7.16	
(138×203×181)	
2NO2NC	
AU-100 (Max.4NO4NC)	
-	

400AF		
MC-265a	MC-330a	MC-400a
●	●	●
3pole		
690V		
1000V		
50/60Hz		
8kV		
1200 operations per hour		
5 mil. operations		2.5 mil. operations
1 mil. operations		0.5 mil. operations
300	350	450
-	-	-
-	-	-
75	100	125
100	125	150
200	250	300
200	250	300
5		
9.2		
6.48×9.92×7.80		
(163×243×198)		
2NO2NC		
AU-100 (Max.4NO4NC)		
-		

MT type Thermal Overload Relays

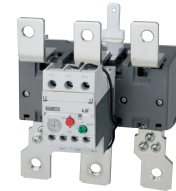

Type	Screws clamp terminals		
Rated operational voltage, Ue	690V		
Rated insulation voltage, Ui	690V		
Rated impulse withstand voltage, Uimp	6kV		
Trip class	10A, 20		
Setting range	65~240A		
Size and weight	Weight	kg	
	Size	inch	
		W×H×D (mm)	



MT-225/□	
●	
690V	
690V	
6kV	
10A, 20	
65~240A	
2.5	
5.79×5.55×7.24	
(147×141×184)	

MT-400/□	
●	
690V	
690V	
6kV	
10A, 20	
85~400A	
2.6	
5.94×6.73×7.79	
(151×171×198)	

* The safety cover of magnetic contactor and thermal overload relay is optional.



800AF

MC-500a	MC-630a	MC-800a
●	●	●
	3pole	
	690V	
	1000V	
	50/60Hz	
	8kV	
	1200 operations per hour	
	2.5 mil. operations	
	0.5 mil. operations	
580	660	900
-	-	-
-	-	-
150	200	200
200	250	300
400	500	600
400	500	600
6		7

22.4
11.22×12.29×9.53
(285×312×242)

2NO2NC

AU-100 (Max.4NO4NC)



MT-800/□

●
690V
690V
6kV
10A, 20
200-800A
11.5
14.17×20.87×8.35 (360×530×212)



2100AF

MC-1400a	MC-1700a	MC-2100a
●	●	●
	3pole	
	1000V	
	1040V	
	50/60Hz	
	8kV	
	3000 operations per hour	
	0.5 mil. operations	
	0.05 mil. operations	
1400	1700	2100
-	-	-
-	-	-
-	-	-
-	-	-
-	-	-

33.8
17×15×9.7
(431×380×246)

2NO2NC

AU-100, AU-100E (Max.4NO4NC)

Contactors & Overload relays

Metasol MC 4P 18 to 85A

MC type Magnetic Contactors



Frame size			
Type	Screw clamp terminal		
Number of poles	4		
Rated operational voltage (Ue)	690V		
Rated insulation voltage (Ui)	690V		
Rated frequency	50/60Hz		
Rated impulse withstand voltage, Uimp	6kV		
Maximum operating rate in operating cycles per hour(AC1)	1800 operations per hour		
Durability	Mechanical		
Electrical	Electrical		
UL rating	Continuous current	A	
(50/60Hz)	Single	110~120V	HP
	Phase	220~240V	HP
		200~208V	HP
	Three	220~240V	HP
		Phase	440~480V
		550~600V	HP
	NEMA Size	Size and	
AC weight	Weight	kg	
	Control	Size	inch
		W×H×D	(mm)
	DC	Weight	kg
Control		Size	inch
		W×H×D	(mm)
Auxiliary(standard)			
Auxiliary	Side Mount		
	Front Mount		



18AF			
MC-6a/4	MC-9a/4	MC-12a/4	MC-18a/4
●			
4pole			
690V			
690V			
50/60Hz			
6kV			
1800 operations per hour			
15 mil. Operations			
0.5 mil. Operations		0.8 mil. Operations	
25	25	25	32
0.5	0.5	0.75	1
1.5	1.5	2	3
2	2	3	5
3	3	5	7.5
5	5	7.5	10
7.5	7.5	10	15
00	00	0	0
0.33			
1.77×2.89×3.11			
(45×73.5×79)			
0.5			
1.77×2.89×4.36			
(45×73.5×110.7)			
-			
UA-1			
AU-2, AU-4			



22AF	
MC-22a/4	
●	
4pole	
690V	
690V	
50/60Hz	
6kV	
1800 operations per hour	
15 mil. Operations	
1 mil. Operations	
32	
2	
3	
7.5	
7.5	
10	
15	
1	
0.4	
1.86×3.15×3.42	
(47.2×80×86.8)	
0.5	
1.86×3.15×4.47	
(47.2×80×113.2)	
-	
AU-1	
AU-2, AU-4	

40AF	
MC-32a/4	MC-40a/4
●	
4pole	
690V	
690V	
50/60Hz	
6kV	
1800 operations per hour	
15 mil. Operations	
1 mil. Operations	
45	50
2	3
5	5
7.5	10
10	10
20	25
20	25
1	1
0.59	
2.32×3.29×3.72	
(59×83.5×94.5)	
0.7	
2.32×3.29×4.76	
(59×83.5×121)	
-	
AU-1	
AU-2, AU-4	

85AF			
MC-50a/4	MC-65a/4	MC-75a/4	MC-85a/4
●			
4pole			
690V			
1000V			
50/60Hz			
8kV			
1800 operations per hour			
12 mil. Operations			
1 mil. Operations			
70	80	90	100
3	5	5	7.5
7.5	10	15	15
10	15	20	25
15	20	25	30
30	40	50	50
30	40	50	50
2	2	2	3
1.2			
3.58×4.86×4.64			
(91×123.5×117.8)			
1.29			
3.58×4.86×4.64			
(91×123.5×117.8)			
-			
AU-1			
AU-2, AU-4			

Contactors & Overload relays

Metasol MC 4P 225 to 800A

MC type Magnetic Contactors



Frame size			
Type	Screw clamp terminal		
Number of poles	4		
Rated operational voltage (Ue)	690V		
Rated insulation voltage (Ui)	1000V		
Rated frequency	50/60Hz		
Rated impulse withstand voltage, Uimp	8kV		
Maximum operating rate in operating cycles per hour(AC1)	1200 operations per hour		
Durability	Mechanical		
Electrical	0.8 mil. Operations		
UL rating (50/60Hz)	Continuous current	A	
	Single	110~120V	HP
	Phase	220~240V	HP
		200~208V	HP
	Three	220~240V	HP
	Phase	440~480V	HP
550~600V		HP	
NEMA Size	Size and		
AC weight	Weight	kg	
	Control	Size	inch
		W×H×D	(mm)
	DC	Weight	kg
Control		Size	inch
	W×H×D	(mm)	
Auxiliary(standard)			
Auxiliary	Side Mount		
	Front Mount		

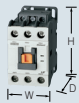

* - FLA = 722 A, LRA = 5618 A

** - FLA = 566 A, LRA = 4495 A

225AF				
MC-100a/4	MC-130a/4	MC-150a/4	MC-185a/4	MC-225a/4
●				
4pole				
690V				
1000V				
50/60Hz				
8kV				
1200 operations per hour				
5 mil. Operations				
0.8 mil. Operations				
160	160	210	230	275
7.5	10	15	15	15
15	20	25	30	40
30	40	40	60	60
30	40	50	60	75
60	75	100	125	150
60	75	100	125	150
3	3	4	4	4
5.6				
6.89×7.99×7.28				
(175×203×185)				
2a2b				
AU-100				
-				



400AF

MC-265a/4	MC-330a/4	MC-400a/4
	●	
	4pole	
	690V	
	1000V	
	50/60Hz	
	8kV	
	1200 operations per hour	
	2.5 mil. Operations	
	0.5 mil. Operations	
300	350	450
-	-	-
-	-	-
75	100	125
100	125	150
200	250	300
200	250	300
5	5	5

9.9
8.11×9.57×8.07
(206×243×205)

2a2b

AU-100
-

800AF

MC-500a/4	MC-630a/4	MC-800a/4
	●	
	4pole	
	690V	
	1000V	
	50/60Hz	
	8kV	
	1200 operations per hour	
	2.5 mil. Operations	
	0.5 mil. Operations	
580	660	900
-	-	-
-	-	-
150	200	200
200	250	300
400	500	600 *
400	500	600 **
6	6	7

26.3
13.62×12.20×9.61
(346×310 ×244)

2a2b

AU-100
-

Contactors & Overload relays

Numbering system

Contactors

MC-6a	/	R	/	AC220		60Hz		1NO1NC		3Pole
Rated current		Version		Coil voltage		Frequency		Auxiliary contact		No. of pole
6a 6A		- Standard		AC 220 AC 220V		60 60Hz		00 None		None 3Pole
⋮		R Reversing		⋮		50 50Hz		11 1NO1NC		4P 4Pole
2100a 2100A				⋮				22 2NO2NC		
9b 9A				DC 24 DC 24V				10 1NO		
⋮								01 1NC		
22b 22A										

Starters

MS-6a	/	R	2H	/	AC220		60Hz		10	/	0.1
Rated current		Contactor version	Relay version		Coil voltage		Frequency		Auxiliary contact		Relay setting current
6a 6A		- Standard	2H Non-differential (2-heater)		AC 220 AC 220V		60 60Hz		00 None		0.1 0.1A
⋮		R Reversing	3H Non-differential (3-heater)		⋮		50 50Hz		11 1a1b		⋮
800a 800A			3K Differential		DC 24 DC 24V				22 2a2b		⋮
9b 9A			3D Class 20						10 1a(1NO)		800 800A
⋮									01 1b(1NC)		
22b 22A											

Thermal Overload Relay

MT-12	/	2H			0.1
Frame size		Relay version			Relay setting current
12 12AF		2H Non-differential (2-heater)			0.1 0.1A
32 32AF		3H Non-differential (3-heater)			⋮
63 63AF		3K Differential			⋮
95 95AF		3D Class 20			800 800A
⋮					
800 800AF					

Optional Accessories

Auxiliary contact unit

UA-1

11

Version

UA-1	Side mount
AU-100	
AU-100E	
UA-2	Front mount(2P)
UA-4	Front mount(4P)

Contact composition

11	1NO+1NC
20	2NO
02	2NC
40	4NO
31	3NO+1NC
22	2NO+2NC
13	1NO+3NC
04	4NC

Note) UA-2: 2NO, 1NO1NC, 2NC
 UA-4: 4NO, 3NO1NC, 4NC,
 2NO2NC, 1NO3NC

Surge absorber

US11

Composition and voltage

1	Varistor+RC	AC/DC 24~48V
2	Varistor+RC	AC/DC 100~125V
3	Varistor+RC	AC/DC 200~240V
4	Varistor+RC	AC 380~440V
5	Varistor+RC	AC 24~48V
6	Varistor+RC	AC 100~125V
11	Varistor	AC 200~240V
12	Varistor	DC 24~48V
13	Varistor	DC 100~125V
14	Varistor	DC 200~220V
22	RC	AC 100~125V

Interlock unit

UR02

Contact composition

02	2NC
00	None

Wire kit for Interlocking

UW32

Frame size

18	18AF
22	22AF
32	32AF
63	63AF
95	95AF

Interlock set (UR+UW)

RK32

Frame size

32	32AF
63	63AF
95	95AF

Separate mounting unit (For relay)

UZ32

Frame size

12	12AF
32	32AF
63	63AF
95	95AF
150	150AF

Remote reset unit (For relay)













UM

Cable length

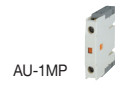
4R	400
5R	500
6R	600
7R	700
9R	900



Mini contactors

6 to 16A

Mini contactors									
3NO main contacts 1 auxiliary contacts		Screw clamp type	Fast-on type	Cage clamp type	Solder pin type				
Frame size		6A	9A	12A	16A				
Screw clamp type	AC coil	GMC-6M	GMC-9M	GMC-12M	GMC-16M				
	DC coil	GMD-6M	GMD-9M	GMD-12M	GMD-16M				
Fast-on type	AC coil	GMC-6MF	GMC-9MF	GMC-12MF	GMC-16MF				
	DC coil	GMD-6MF	GMD-9MF	GMD-12MF	GMD-16MF				
Cage clamp type	AC coil	GMC-6MC	GMC-9MC	GMC-12MC	GMC-16MC				
	DC coil	GMD-6MC	GMD-9MC	GMD-12MC	GMD-16MC				
Solder pin type	AC coil	GMC-6MP	GMC-9MP	GMC-12MP	GMC-16MP				
	DC coil	GMD-6MP	GMD-9MP	GMD-12MP	GMD-16MP				
Ratings / IEC60947-4		kW	A	kW	A	kW	A	kW	A
AC1	200/240V	1.5	7	2.2	9	3	12	4	15
	380/440V	2.2	6	4	9	5.5	12	7.5	16
	500/550V	3	5	3.7	6	4	7	5.5	9
	690V	3	4	4	5	4	5	4	5
Ratings / UL508		hp	A	hp	A	hp	A	hp	A
continuous current		I _{th} = 20A (maximum for cage clamp type is 10A)							
single phase	120V	1/2		1/2		1 *		-	
	230V/240V	1		1.5		2 **		-	
three phase	240V	1.5		3		3		-	
	480V	3		5		7.5 ***		-	
	600V	3		5		7.5		-	
Wire Range : Copper, 75°C, Stranded, 18-12AWG									
NEMA size		00		00		00		0	
Additional auxiliary contacts		Screw clamp type		Fast-on type		Cage clamp type		Solder pin type	
2-pole, Front mount	AU-2M		AU-2MF		AU-2MC				
	AU-4M		AU-4MF		AU-4MC				
	AU-1M		AU-1MF		AU-1MC				
4-pole, Front mount									
2-pole, Side mount									

Note) * = 1/2 for cage clamp type, ** = 1.5hp for cage clamp type, *** = 5hp for cage clamp type
16AF : not approved from UL

Overload Relays

Bimetallic style Type GT		Setting ranges (A)	0.1 - 0.16 0.16 - 0.25 0.25 - 0.4 0.4 - 0.63 0.63 - 1 1 - 1.6 1.6 - 2.5 2.5 - 4	4 - 6 5 - 8 6 - 9 7 - 10 9 - 13 12 - 16		Base for separate mount
	Differential	GTK-12M				
	Non-differential (3-heater)	GTH-12M/3				
	Non-differential (2-heater)	GTH-12M				

Numbering system

Catalog Numbering [Mini-MC]

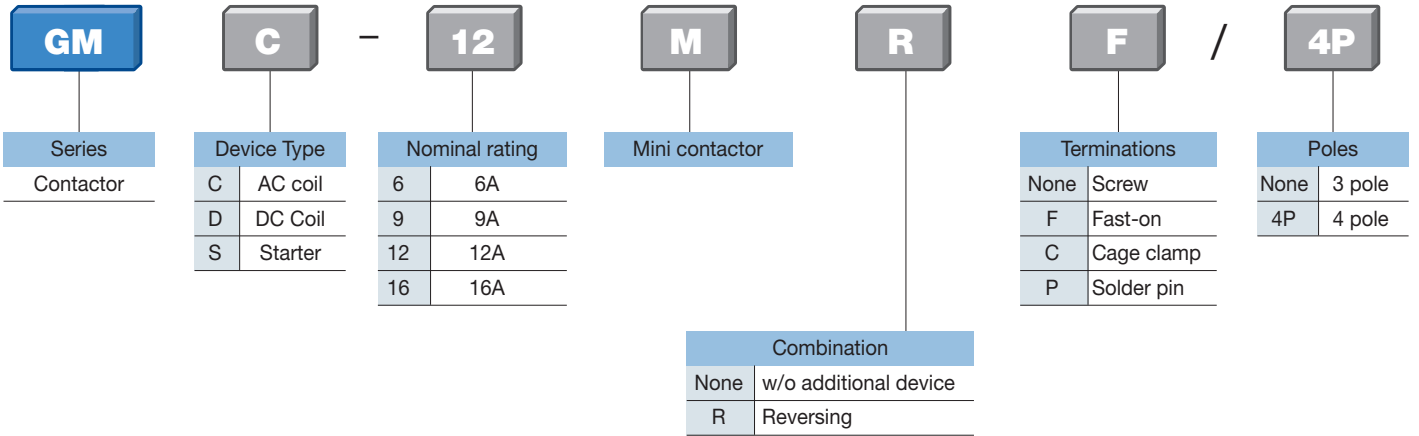

Catalog Numbering [Mini-TOR]

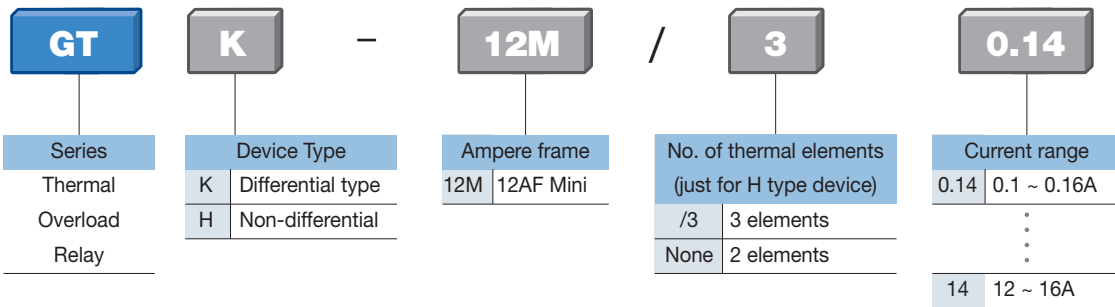

Manual motor starters

Technical information

Manual motor controller (UL 508, CSA C22.2 as Manual motor controllers)

Combination Motor Controller

- Group Installation
- Type E starter



MMS 32S

Rated operational current I_e [A]		0.16	0.25	0.4	0.63	1	1.6	2.5	4	6	8	10	13	17	22	26	32	40	
Max. short-circuit current																			
240V	[kA]	100	100	100	100	100	100	100	100	100	100	50	50	40	30	30	20	20	
480V	[kA]	50	50	50	50	50	50	50	50	25	25	10	10	10	10	7.5	7.5	7.5	
600V	[kA]	10	10	10	10	10	10	10	5	5	5	5	5	5	5	5	5	5	
Motor load																			
1 Phase	115V	[HP]	-	-	-	-	-	-	1/8	1/4	1/3	1/2	1/2	1	1½	2	2	3	
	230V	[HP]	-	-	-	-	1/10	1/6	1/3	1/2	1	1½	2	3	3	3	5	7½	
3 Phase	200V	[HP]	-	-	-	-	-	1/2	3/4	1	2	2	3	3	5	7½	7½	10	
	230V	[HP]	-	-	-	-	-	1/2	3/4	1½	2	3	3	5	7½	7½	10	10	
	460V	[HP]	-	-	-	-	3/4	1	2	3	5	5	7½	10	15	15	20	30	
	575V	[HP]	-	-	-	-	1/2	3/4	1½	3	5	5	7½	10	15	20	30	30	
Max. fuse size [A]		1	1	1	3	6	10	15	20	30	40	50	60	80	100	125	125		
Max. breaker size [A]		15	15	15	15	15	15	15	15	20	30	40	50	60	80	100	125	125	

MMS 63S

Rated operational current I_e [A]		10	13	17	22	26	32	40	50	63	65	
Max. short-circuit current												
240V	[kA]	100	100	100	100	100	100	100	100	100	100	
480V	[kA]	50	50	40	40	40	40	40	40	40	40	
600V	[kA]	10	10	10	10	10	10	10	10	10	10	
Motor load												
1 Phase	115V	[HP]	1/2	1/2	1	1½	2	2	3	3	5	5
	230V	[HP]	1½	2	3	3	3	5	7½	10	10	10
3 Phase	200V	[HP]	2	3	3	5	7½	7½	10	15	20	20
	230V	[HP]	3	3	5	7½	7½	10	10	15	20	20
	460V	[HP]	5	7½	10	15	15	20	30	30	40	40
	575V	[HP]	7½	10	15	20	20	30	30	40	60	60
Maximum rated current of fuse or breaker [A]		600	600	600	600	600	600	600	600	600	600	

MMS 100S

Rated operational current I_e [A]		17	22	26	32	40	50	63	75	90	100	
Max. short-circuit current												
240V	[kA]	100	100	100	100	100	100	100	100	100	100	
480V	[kA]	50	50	50	50	50	50	40	40	40	40	
600V	[kA]	10	10	10	10	10	10	10	10	10	10	
Motor load												
1 Phase	115V	[HP]	1	1½	2	2	3	3	5	5	7½	10
	230V	[HP]	3	3	3	5	7½	10	10	15	20	20
3 Phase	200V	[HP]	3	5	7½	7½	10	15	20	20	25	30
	230V	[HP]	5	7½	7½	10	10	15	20	25	30	30
	460V	[HP]	10	15	15	20	30	30	40	50	60	75
	575V	[HP]	15	20	20	30	30	40	60	60	75	100
Maximum rated current of fuse or breaker [A]		1000	1000	1000	1000	1000	1000	1000	1000	1000	1000	

In case of 1-phase use in series as shown below

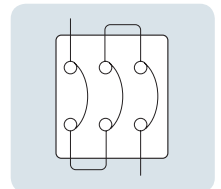

Combination Motor Controller

- Group Installation
- Type E starter



MMS 32H

Rated operational current I_e [A]		0.16	0.25	0.4	0.63	1	1.6	2.5	4	6	8	10	13	17	22	26	32	40	
Max. short-circuit current																			
240V	[kA]	100	100	100	100	100	100	100	100	100	100	100	100	100	100	100	100	100	
480V	[kA]	65	65	65	65	65	65	65	65	65	65	65	65	30	30	30	30	30	
600V	[kA]	25	25	25	25	25	25	25	25	25	25	25	25	10	10	10	10	10	
Motor load																			
1 Phase	115V [HP]	-	-	-	-	-	-	-	1/8	1/4	1/3	1/2	1/2	1	1½	2	2	3	
	230V [HP]	-	-	-	-	-	1/10	1/6	1/3	1/2	1	1½	2	3	3	3	5	7½	
3 Phase	200V [HP]	-	-	-	-	-	-	1/2	3/4	1	2	2	3	3	5	7½	7½	10	
	230V [HP]	-	-	-	-	-	-	1/2	3/4	1½	2	3	3	5	7½	7½	10	10	
	460V [HP]	-	-	-	-	-	3/4	1	2	3	5	5	7½	10	15	15	20	30	
	575V [HP]	-	-	-	-	1/2	3/4	1½	3	5	5	7½	10	15	20	20	30	30	
Maximum rated current of fuse or breaker		[A]	500	500	500	500	500	500	500	500	500	500	500	500	500	500	500	500	

MMS 63H

Rated operational current I_e [A]		10	13	17	22	26	32	40	50	63	65
Max. short-circuit current											
240V	[kA]	100	100	100	100	100	100	100	100	100	100
480V	[kA]	65	65	50	50	50	50	50	50	50	50
600V	[kA]	25	25	10	10	10	10	10	10	10	10
Motor load											
1 Phase	115V [HP]	1/2	1/2	1	1½	2	2	3	3	5	5
	230V [HP]	1½	2	3	3	3	5	7½	10	10	10
3 Phase	200V [HP]	2	3	3	5	7½	7½	10	15	20	20
	230V [HP]	3	3	5	7½	7½	10	10	15	20	20
	460V [HP]	5	7½	10	15	15	20	30	30	40	40
	575V [HP]	7½	10	15	20	20	30	30	40	60	60
Maximum rated current of fuse or breaker		[A]	600	600	600	600	600	600	600	600	600

MMS 100H

Rated operational current I_e [A]		17	22	26	32	40	50	63	75	90	100
Max. short-circuit current											
240V	[kA]	100	100	100	100	100	100	100	100	100	100
480V	[kA]	65	65	65	65	65	65	50	50	50	50
600V	[kA]	25	25	25	20	20	20	10	10	10	10
Motor load											
1 Phase	115V [HP]	1	1½	2	2	3	3	5	5	7½	10
	230V [HP]	3	3	3	5	7½	10	10	15	20	20
3 Phase	200V [HP]	3	5	7½	7½	10	15	20	20	25	30
	230V [HP]	5	7½	7½	10	10	15	20	25	30	30
	460V [HP]	10	15	15	20	30	30	40	50	60	75
	575V [HP]	15	20	20	30	30	40	60	60	75	100
Maximum rated current of fuse or breaker		[A]	1000	1000	1000	1000	1000	1000	1000	1000	1000

In case of 1-phase use in series as shown below

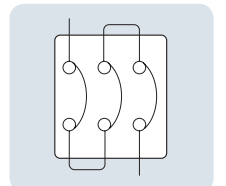

Manual motor starters

Technical information

Manual motor controller (UL508)



MMS 32S

Rated operational current I_e [A]		0.16	0.25	0.4	0.63	1	1.6	2.5	4	6	8	10	13	17	22	26	32	40	
Max. short-circuit current																			
240V	[kA]	100	100	100	100	100	100	100	100	100	100	50	50	40	30	30	20	20	
480V	[kA]	50	50	50	50	50	50	50	50	25	25	10	10	10	10	7.5	7.5	7.5	
600V	[kA]	10	10	10	10	10	10	10	5	5	5	5	5	5	5	5	5	5	
Motor load																			
1 Phase	115V	[HP]	-	-	-	-	-	-	1/8	1/4	1/3	1/2	1/2	1	1½	2	2	3	
	230V	[HP]	-	-	-	-	1/10	1/6	1/3	1/2	1	1½	2	3	3	3	5	7½	
3 Phase	200V	[HP]	-	-	-	-	-	1/2	3/4	1	2	2	3	3	5	7½	7½	10	
	230V	[HP]	-	-	-	-	-	1/2	3/4	1½	2	3	3	5	7½	7½	10	10	
	460V	[HP]	-	-	-	-	3/4	1	2	3	5	5	7½	10	15	15	20	30	
	575V	[HP]	-	-	-	1/2	3/4	1½	3	5	5	7½	10	15	20	20	30	30	
Max. fuse size		[A]	1	1	1	3	6	10	15	20	30	40	50	60	80	100	125	150	
Max. breaker size		[A]	15	15	15	15	15	15	15	20	30	40	50	60	80	100	125	150	

MMS 63S

Rated operational current I_e [A]		10	13	17	22	26	32	40	50	63	65
Max. short-circuit current											
240V	[kA]	100	100	100	100	100	100	100	100	100	100
480V	[kA]	25	25	25	25	25	25	25	25	25	25
600V	[kA]	10	10	10	10	10	10	10	10	10	10
Motor load											
1 Phase	115V	[HP]	1/2	1/2	1	1½	2	2	3	3	5
	230V	[HP]	1½	2	3	3	3	5	7½	10	10
3 Phase	200V	[HP]	2	3	3	5	7½	7½	10	15	20
	230V	[HP]	3	3	5	7½	7½	10	10	15	20
	460V	[HP]	5	7½	10	15	15	20	30	30	40
	575V	[HP]	7½	10	15	20	20	30	30	40	60
Max. fuse size		[A]	40	50	60	80	100	125	150	200	250
Max. breaker size		[A]	40	50	60	80	100	125	150	200	250

MMS 100S

Rated operational current I_e [A]		17	22	26	32	40	50	63	75	90	100
Max. short-circuit current											
240V	[kA]	100	100	100	100	100	100	100	100	100	100
480V	[kA]	25	25	25	25	25	25	25	25	25	25
600V	[kA]	10	10	10	10	10	10	10	10	10	10
Motor load											
1 Phase	115V	[HP]	1	1½	2	2	3	3	5	5	7½
	230V	[HP]	3	3	3	5	7½	10	10	15	20
3 Phase	200V	[HP]	3	5	7½	7½	10	15	20	20	25
	230V	[HP]	5	7½	7½	10	10	15	20	25	30
3 Phase	460V	[HP]	10	15	15	20	30	30	40	50	60
	575V	[HP]	15	20	20	30	30	40	60	60	75
Max. fuse size		[A]	60	80	100	125	150	200	250	300	350
Max. breaker size		[A]	60	80	100	125	150	200	250	300	350

In case of 1-phase use in series as shown below

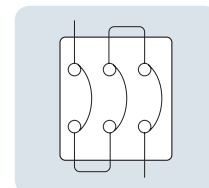



MMS 32H

Rated operational current I_e [A]		0.16	0.25	0.4	0.63	1	1.6	2.5	4	6	8	10	13	17	22	26	32	40	
Max. short-circuit current																			
240V	[kA]	100	100	100	100	100	100	100	100	100	100	100	100	100	100	100	100	100	100
480V	[kA]	50	50	50	50	50	50	50	50	50	50	50	50	30	30	30	30	30	30
600V	[kA]	10	10	10	10	10	10	10	10	10	10	10	10	10	10	10	10	10	10
Motor load																			
1 Phase	115V [HP]	-	-	-	-	-	-	-	1/8	1/4	1/3	1/2	1/2	1	1½	2	2	3	
	230V [HP]	-	-	-	-	-	1/10	1/6	1/3	1/2	1	1½	2	3	3	3	5	7½	
3 Phase	200V [HP]	-	-	-	-	-	-	1/2	3/4	1	2	2	3	3	5	7½	7½	10	
	230V [HP]	-	-	-	-	-	-	1/2	3/4	1½	2	3	3	5	7½	7½	10	10	
	460V [HP]	-	-	-	-	-	3/4	1	2	3	5	5	7½	10	15	15	20	30	
	575V [HP]	-	-	-	-	1/2	3/4	1½	3	5	5	7½	10	15	20	20	30	30	
Max. fuse size		[A]	1	1	1	1	3	6	10	15	20	30	40	50	60	80	100	125	150
Max. breaker size		[A]	15	15	15	15	15	15	15	20	30	40	50	60	80	100	125	150	150

MMS 63H

Rated operational current I_e [A]		10	13	17	22	26	32	40	50	63	65	
Max. short-circuit current												
240V	[kA]	100	100	100	100	100	100	100	100	100	100	
480V	[kA]	50	50	50	50	50	50	50	50	50	50	
600V	[kA]	10	10	10	10	10	10	10	10	10	10	
Motor load												
1 Phase	115V [HP]	1/2	1/2	1	1½	2	2	3	3	5	5	
	230V [HP]	1½	2	3	3	3	5	7½	10	10	10	
3 Phase	200V [HP]	2	3	3	5	7½	7½	10	15	20	20	
	230V [HP]	3	3	5	7½	7½	10	10	15	20	20	
	460V [HP]	5	7½	10	15	15	20	30	30	40	40	
	575V [HP]	7½	10	15	20	20	30	30	40	60	60	
Max. fuse size		[A]	40	50	60	80	100	125	150	200	250	250
Max. breaker size		[A]	40	50	60	80	100	125	150	200	250	250

MMS 100H

Rated operational current I_e [A]		17	22	26	32	40	50	63	75	90	100
Max. short-circuit current											
240V	[kA]	100	100	100	100	100	100	100	100	100	100
480V	[kA]	50	50	50	50	50	50	50	50	50	50
600V	[kA]	10	10	10	10	10	10	10	10	10	10
Motor load											
1 Phase	115V [HP]	1	1½	2	2	3	3	5	5	7½	10
	230V [HP]	3	3	3	5	7½	10	10	15	20	20
3 Phase	200V [HP]	3	5	7½	7½	10	15	20	20	25	30
	230V [HP]	5	7½	7½	10	10	15	20	25	30	30
	460V [HP]	10	15	15	20	30	30	40	50	60	75
	575V [HP]	15	20	20	30	30	40	60	60	75	100
Max. fuse size		[A]	60	80	100	125	150	200	250	300	400
Max. breaker size		[A]	60	80	100	125	150	200	250	300	400

In case of 1-phase use in series as shown below

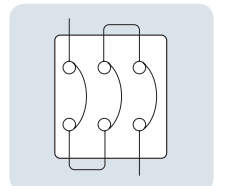

Manual motor starters

Numbering system

Numbering [Manual Motor Starter]

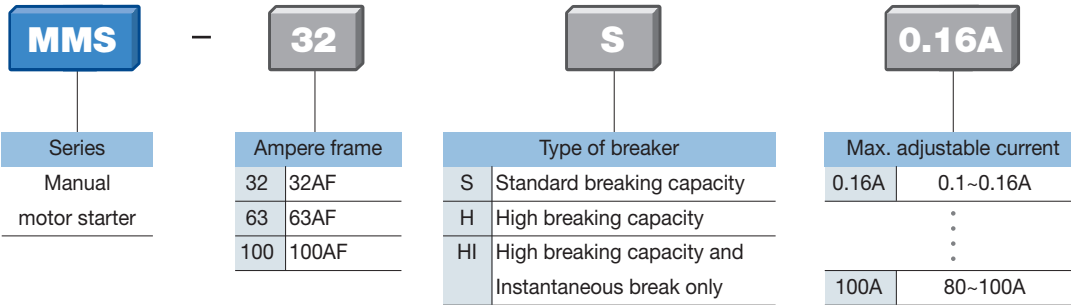



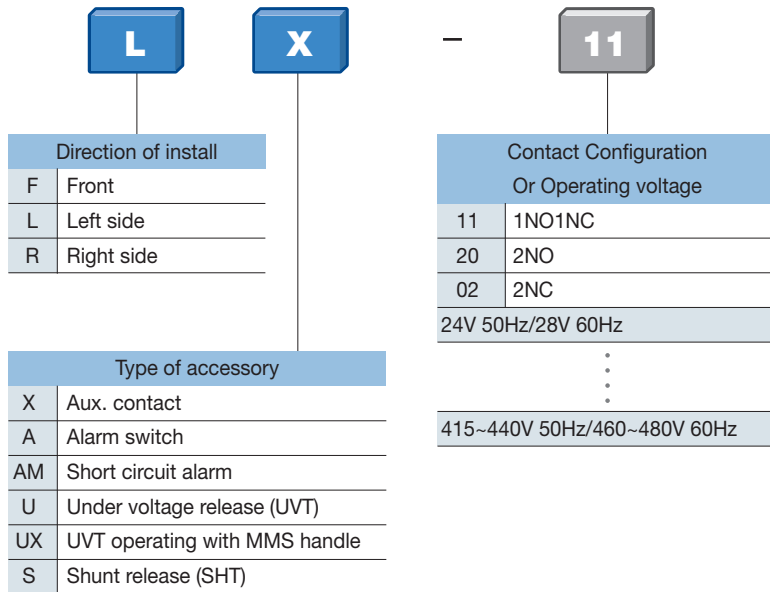



Catalog Numbering [Aux. contact, Alarm, Release unit]



Electronic motor protection relays

GMP Series

Ratings										
Model		GMP22-2P (1c)	GMP22-2P(1a1b)	GMP22-3P/3PR	GMP22-2S	GMP22-3S/3SR	GMP22-2T	GMP22-3T/3TR		
Type		Pin type			Screw type		Tunnel type			
No. of CT		2CT	2CT	3CT	2CT	3CT	2CT	3CT		
Protection	Overcurrent	●	●	●	●	●	●	●		
	Phase failure ^{Note1)}	●	●	●	●	●	●	●		
	Lock/Stall	●	●	●	●	●	●	●		
	Phase unbalance	-	-	●	-	●	-	●		
	Reverse phase	-	-	●(3PR)	-	●(3PR)	-	●(3PR)		
Current setting range (A)		0.3~1.5, 1~5, 4.4~22								
Operating time characteristics		Inverse time (GMP22-2PD: Definite time)								
Time setting (sec)	Inverse time	0~30 sec								
	Definite	D-time	0.2~60 sec for GMP22-2PD							
		O-time	5sec (Fixed) for GMP22-2PD							
	Reset-time	Manual reset								
Tolerance	Current	±5%								
	Time	±5%(or±0.5sec)								
Control power	Voltage	AC 110V/220V(±10%)	AC 100~260V(±10%)							
	Frequency	50/60Hz								
Aux. contact	Contact ^{Note 3)}	1SPDT (1c)		2SPST (1a1b)						
	Ratings	5A/250VAC Resistive load		3A/250VAC Resistive load						
	Operate	(95 ⇄ 96 Close)		(95 ⇄ 96 Close)		(97 ⇄ 98 Open)				
Insulation resistance		Min 100MΩ at 500Vdc								
Surge endurance (IEC 61000-4-5)		5kV Apply the standard wave								
Fast transient burst (IEC 61000-4-4)		2kV								
Environment	Operation	-25~70℃								
Temperature	Storage	-30~80℃								
	Relative humidity	30~90%RH(No freezing)								
Trip indicator		Red LED	Red/Green LED		Red LED	Red/Green LED	Red LED	Red/Green LED		
Dimension	W×H×D	inch	1.73×2.80×3.07		2.09×3.07×3.44		2.87×2.68×3.44		2.09×1.50×3.44	
			(mm)	(44×71×78)		(53×78×87.5)		(53×68×87.5)		(53×38×87.5)
Mounting type		Direct mount onto a Metasol MC (MC-9b-22b)			Separate mount (Screw or Din-rail) ^{Note2)}					
Certification		UL, cUL, CE								

Note) 1. When it is 2CT model, only two-phase protection is available

2. The bracket for Din-rail mount is optional

3. When power applied Aux. contact operate

Electronic motor protection relays

GMP Series

Ratings



Model		GMP40-2P	GMP40-3P/3PR	GMP40-2S	GMP40-3S/3SR	GMP40-2T	GMP40-3T/3TR	GMP80-2S	GMP80-3S/3SR	GMP60T	GMP60TE	
Type		Pin type *		Screw type		Tunnel type		Screw type		Tunnel type		
No. of CT		2CT	3CT	2CT	3CT	2CT	3CT	2CT	3CT	2CT		
Protection	Overcurrent	●	●	●	●	●	●	●	●	●		
	Phase failure ^{Note1)}	●	●	●	●	●	●	●	●	●		
	Lock/Stall	●	●	●	●	●	●	●	●	●		
	Phase unbalance	-	●	-	●	-	●	-	●	-		
	Reverse phase	-	●(3PR)	-	●(3PR)	-	●(3PR)	-	●(3PR)	-		
Current setting range(A)		4~20, 8~40						16~80		0.5~6, 3~30, 5~60		
Operating time characteristics		Inverse time characteristics, Definite (GMP-PD Type)									Definite	
Time setting (sec)	Inverse time	0~30 sec									-	
	Definite D-time	0.2~60 sec (GMP40-2PD)									0.2~30 sec	
	O-time	5sec (Fixed) (GMP40-2PD)									0.2~30 sec	5 sec (Fixed)
	Reset time	Manual reset (Auto Reset type : GMP□-A)									-	GMP-TA
Tolerance	Current	±5%									±5%	
	Time	±5% (or ±0.5 sec)									±5% (or ±5 sec)	
Control power	Voltage ^{Note3)}	AC 100~260V									AC 110V/260V	
	Frequency	50/60Hz									50/60Hz	
Aux. contact	Contact ^{Note4)}	2SPST (1a1b)									1SPDT (1c)	
	Ratings	3A/250VAC Resistive load									1A/250VAC Resistive load	
	Operate	(95 ± 96 Close)			(97 ± 98 Open)						-	
Insulation resistance		Min 100MΩ at 500Vdc									Min 100MΩ at 500Vdc	
Surge endurance (IEC 61000-4-5)		5kV Apply the standard wave									5kV Apply the standard wave	
Fast transient burst (IEC 61000-4-4)		2kV									2kV	
Environment	Operation	-25~70°C									-25~70°C	
Temperature	Storage	-30~80°C									-30~80°C	
	Relative humidity	30~90%RH (No freezing)									30~90%RH (No freezing)	
Trip indicator		Red LED	Red/Green LED	Red LED	Red/Green LED	Red LED	Red/Green LED	Red LED	2Red LEDs	Red LED		
Dimension	W×H×D inch (mm)	2.09×3.07×3.44 (53×78×87.5)		2.09×2.68×3.44 (53×68×87.5)		2.09×2.68×3.44 (53×38×87.5)		3.50×3.05×3.83 (89×77.5×97.4)		2.83×2.64×2.72 (72×67×69)		
		Direct mount onto a Metasol MC (MC-32a, 40a)		Separate mount (Screw or Din-rail)						Separate mount (Screw or Din-rail)		
Certification		UL, cUL, CE										

Note) 1. When it is 2CT model, only two-phase protection is available.

2. GMP60T/TE: AC24V, 48V or 380V, 50/60Hz types a option.

3. When power applied the Aux. contact operate.

Numbering system

GMP series - ordering

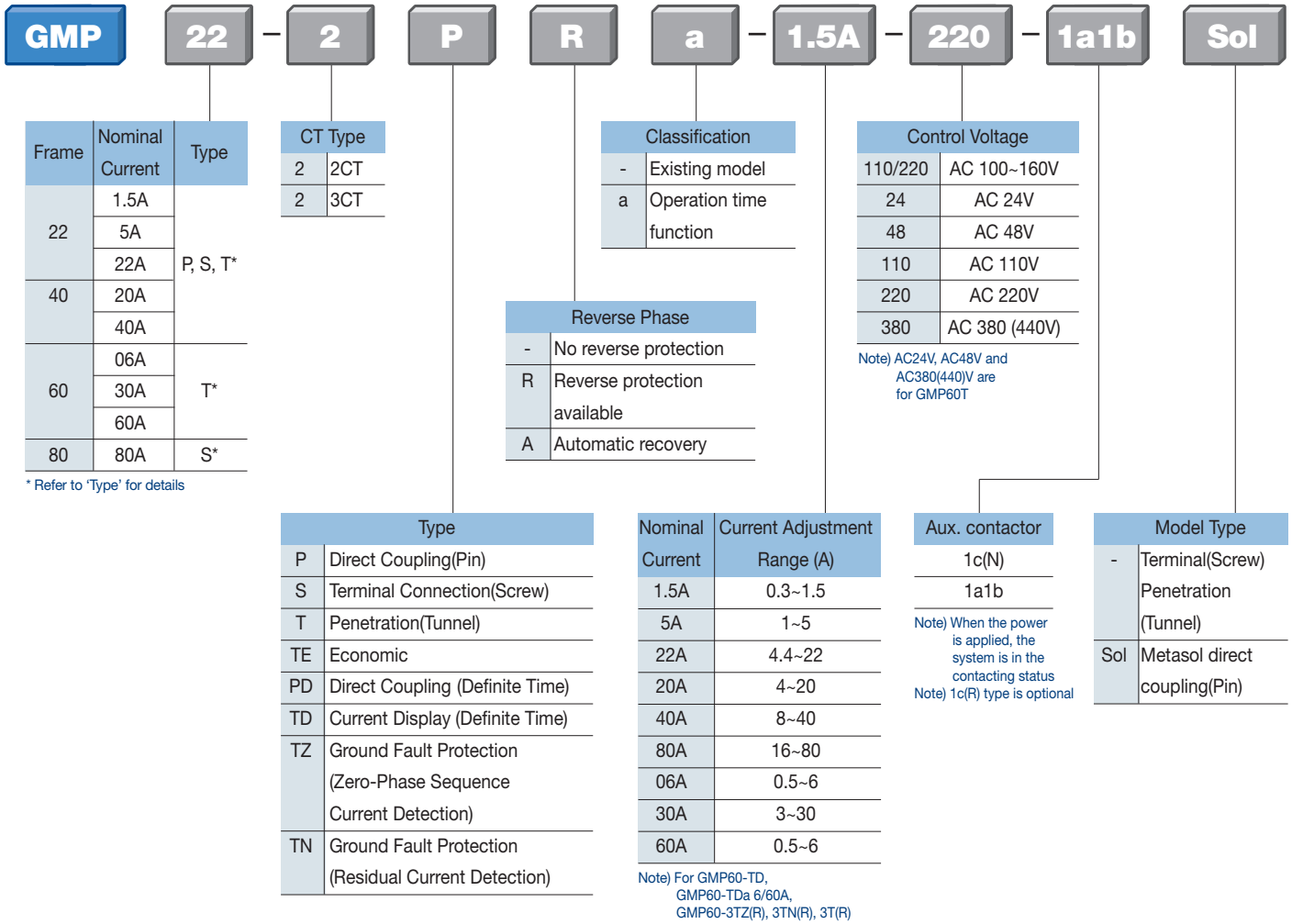

Electronic motor protection relays

DMP Series

Ratings		Screw type		Tunnel type	
		Model	DMP06-S/SZ/SI	DMP60-Sa/SZa	DMP06-T/TZ/TI
Wiring		Screw type		Tunnel type	
Panel mount		Unit or Extension ^{Note1)}		Unit or Extension ^{Note1)}	
Operation time		Inverse/Definite		Inverse/Definite	
Protection	Over current	According to the setting time		According to the setting time	
	Phase failure	3 sec		3 sec	
	Reverse phase	Within 0.1 sec		Within 0.1 sec	
	Lock/Stall	Within 0.5 sec		Within 0.5 sec	
	Phase unbalance	5 sec		5 sec	
	Under current	3 sec		3 sec	
	Ground fault	Within 0.05~1 sec. (DMP -Z/Za)		Within 0.05~1 sec. (DMP -T/Ta)	
	Short circuit	Within 50ms (DMP -SI)		Within 50ms (DMP -TI)	
Alarm		Variable (60~110% of the setting current)		Variable (60~110% of the setting current)	
Current setting range (A)		6: 0.5~6A, 60: 5~60A		6: 0.5~6A, 60: 5~60A	
Time setting (sec)	Definite D time	0~60 sec		0~60 sec	
	O time	0~30 sec		0~30 sec	
	Inverse time	0~60 sec		0~60 sec	
	A time (Reset)	Manual reset		Manual reset	
Tolerance	Current	±5%		±5%	
	Time	±5% (or±0.5 sec)		±5% (or±0.5 sec)	
Operating power	Voltage	AC 110V or 220V, 50/60Hz		AC 110V or 220V, 50/60Hz	
Aux. contact		S, SI Type: 2a1b, SZ Type: 2a, 1a1b, 2b		T, TI Type: 2a1b, TZ Type: 2a, 1a1b, 2b	
Insulation resistance		Over DC 500V 100MΩ		Over DC 500V 100MΩ	
Surge impulse voltage (IEC 61000-4-5)		5kV		5kV	
Fast transient burst (IEC 61000-4-4)		2kV		2kV	
Environment Temperature	Operation	-25~70℃		-25~70℃	
	Storage	-30~80℃		-30~80℃	
	Relative humidity	30~90% RH (No freezing)		30~90% RH (No freezing)	
Display	7-Segment	Cause of a fault, Current		Cause of a fault, Current	
	Bar-Graph	60~110% of real load current		60~110% of real load current	
Mounting type		35mm Din-rail/Panel		35mm Din-rail/Panel	
Certification		UL, cUL, CE (Except DMP36 type), KR, LR, ABS			

Note) 1. In extension type, the digital EMPR is calibrated with combining the display part and main body so, please cautious not to combine the display part and main body with different part No.

2. Zero current sensing by zero sequence CT and Residual circuit.

3. DMP-a Type option : Operating time, Fault event save, 3phase current Ampere meter Function

Numbering system

DMP series - Ordering

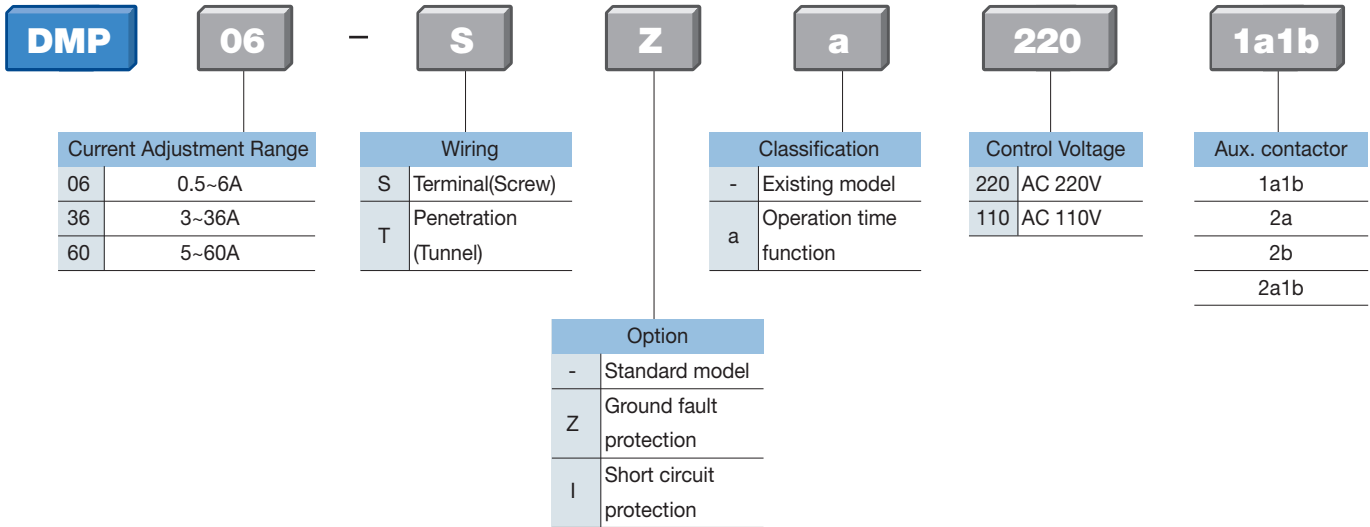

Aux. contact		95-96	97-98	07-08
SE - standard		b(OL) *	a(OL)	a(AL)
SEZ - ground fault protection	2a	a(OL)	a(GR)	ZCT input
	2b	b(OL)	b(GR)	
SEI - short circuit protection		b(OL) *	a(OL)	a(SR)

* Contact *I when power applied

Electronic motor protection relays

Accessories

CT, ZCT, Cable and Terminal

CT Ratings

Type	2CT	3CT	
CT ratio	100 : 5A	DCT-100	
	150 : 5A	DCT-150	SCT-150
	200 : 5A	DCT-200	SCT-200
	300 : 5A	DCT-300	SCT-300
	400 : 5A	DCT-400	SCT-400
Class	1.0		
Burden	5VA		
Insulation voltage	600VAC		
Insulated impulse voltage	2kV		
Insulation resistance	10MΩ(DC 500V Megger)		
Mounting	Panel		

Note) Please use DCT for LS Electronic Motor Protection Relay only.

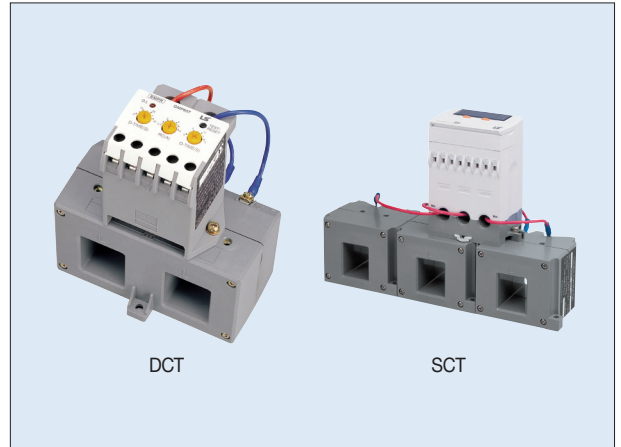

DCT

SCT

ZCT (Zero Sequence CT) Ratings

Type	Diameter (A)	Ratio	Diameter (A)
LZT-030	30	0.5	100mA/40~55mV
LZT-050	50	0.7	
LZT-065	65	0.9	200mA/100mV
LZT-080	80	1.5	

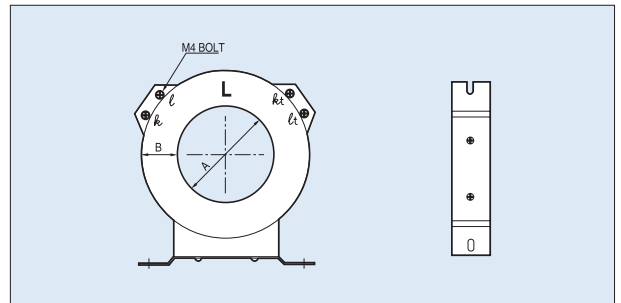

Cable

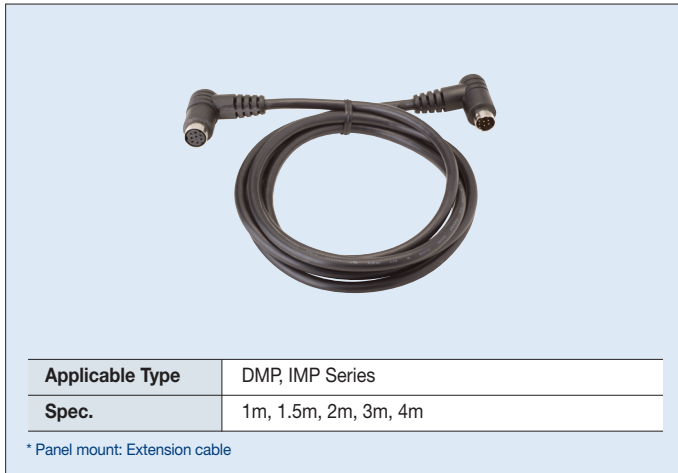

Terminal Block

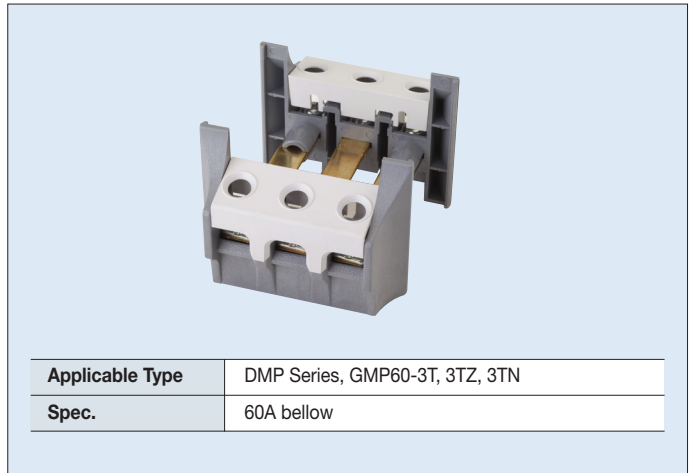

Vacuum Circuit Breakers

Susol VCB Series

4.76/15kV 25/31.5kA 1200/2000A

VL-05/15



Item			VL-05□25, 32□12, 20				VL-15□25, 32□12, 20			
Rated voltage	Ur (kV)		4.76				15			
Rated current	Isc (kA)		1200	2000	1200	2000	1200	2000	1200	2000
Pole distance	(mm)		150	210	150	210	150	210	150	210
Weight(H, Cradle)	(kg)		430	510	430	510	430	510	430	510
Weight(H, Circuit Cradle)	(kg)		115	140	115	140	115	140	115	140
Weight(P, Circuit Cradle)	(kg)		85	130	85	130	85	130	85	130
Rated frequency	fr (Hz)		60							
Rated interrupting current	Ik (kA)		25	31.5	25	31.5	25	31.5	25	31.5
Rated interrupting capacity	(MVA)		207	260	207	260	650	820	650	820
Rated short-time current	Ik/tk (kA)		31.5/2s							
Rated making current	Ip (kA)		81.9							
Rated interrupting time	(cycle)		3							
Withstand	Frequency	Ud (kV)	19				95			
Voltage	Impulse	Ud (kV/1.2×50μs)	60				95			
Operating duty			O-0.3s-CO-3min-CO							
Rated Closing Control voltage	(V)		DC 24~30V, DC 48~60V, DC110V, DC125V, DC220V, AC 48V, AC100~130V, AC220~250V							
Rated Trip Control voltage	(V)		DC 24~30V, DC 48~60V, DC110V, DC125V, DC220V, AC 48V, AC100~130V, AC220~250V							
Standard aux. contacts			4a4b, 10a10b							
Rated opening time	(s)		0.04							
No-load closing time	(s)		0.06							
Mechanical Endurance	(Operations)		10,000							
Electrical Endurance			Reference Standard							
Capacitive current switching			C2							
Life time	Electrical	(Operations)	Reference Electrical Life Graph							
Installation	Fixed		P Type							
	Draw-out		H Type							
Applicable standard			IEEE Std C37.09, IEEE Std C37.20.2, ANSI C37.54, ANSI C37.55							

* Lifetime with maintenance.

** H type is a box type cradle with CB compartment style structure.

Vacuum Circuit Breakers

Numbering system

4.76/15kV 25/31.5kA 1200/2000A

Breaker

VL	15	H	32	A	20
Basic model name	Rated voltage (kV)	Version	Interrupting current (kA)	Phase distance/Compatibility	Rated current (A)
VL Susol VCB	05 4.76 15 15	P Fixed H H type drawout (for MESH)	25 25 32 31.5	A 150 B 210	12 1200A 20 2000A

* A is for 1200A only
B is for 2000A only

M1	C1	T1	SB2	U1	A	147
Motor control voltage		Trip coil voltage		UVT	Other accessories <small>Note)</small>	
M0 motor none M1 DC 110V M2 DC 220V M3 DC 125V M4 DC 24V~30V M5 AC 48V~60V M6 AC 48V M7 AC 100V~130V M8 AC 200V~250V		T0 Trip Coil none T1 DC 110V T2 DC 220V T3 DC 125V T4 DC 24V~30V T5 AC 48V~60V T6 AC 48V T7 AC 100V~130V T8 AC 200V~250V		U0 UVT none U1 DC 110V U2 DC 220V U3 DC 125V U4 DC 24V~30V U5 AC 48V~60V U6 AC 48V U7 AC 100V~130V U8 AC 200V~250V	A1 Secondary Trip coil A2 Secondary Trip Coil with TCS Contact A3 Position s/w(Test:1a1b,Service:2b) A4 Position s/w(Test:2a,Service:2a) A5 Position s/w(Test:1a1b,Service:1a1b) A6 Latch checking s/w A7 Keylock A8 Button Padlock A9 Button cover AA Lead Wire AB User Plug(Part) AC Plug Interlock AD Padlock(H type) AE MOC AF Locking Magnet AJ Door Interlock AO Lead Wire Special Color(Blue) AP Truck removed AR 3 Position AS Back to back switching AT Low Energy Trip Device 25mJ AU Low Energy Trip Device 100mJ AV CT operated coil 1A AW CT operated coil 5A	
	Closing coil voltage		Connector and wire			
	C0 Without closing coil C1 DC 110V C2 DC 220V C3 DC 125V C4 DC 24V~30V C5 DC 48V~60V C6 AC 48V C7 AC 100V~130V C8 AC 200V~250V		SA2 SA4 SB2 SA4 DA1 DB1 SB6 DA1 DB1	Standard Flame retardant	A type connector, 4a4b A type connector, 10a10b B type connector, 4a4b B type connector, 10a10b Dummy A type connector Dummy B type connector B type connector, 4a4b Dummy A type connector Dummy B type connector	

Note)

- In the case of selecting accessories such as A1(Secondary coil), A4(position S/W 2a2a), A7(key lock), A147 is type name in the ordering.
- Unable to select A1(Secondary Trip Coil), U1~U8(UVT) simultaneously.
- A3(Position S/W 1a3b), A4(Position S/W 2a2b) and A5(Position S/W 2a2b) can not be selected simultaneously.
- A8(Button Padlock) and A9(Button Cover) can not be selected simultaneously.
- When A1(Secondary Trip Coil) is selected the maximum available auxiliary contacts are 9a9b.
- When A2(Secondary Trip Coil with TCS Contact) is selected the maximum available auxiliary contacts are 4a3b, 9a8b.
- The flame retardant wire is applicable to auxiliary contacts 4a4b, not to 10a10b.
- Locking magnet of breaker use the same control power supply as motor.
- In case of UL Type, AC(Plug Interlock), AD(Padlock(H type)) and AE(MOC) are included as standard.

Numbering system

4.76/15kV 25/31.5kA 1200/2000A

Cradle

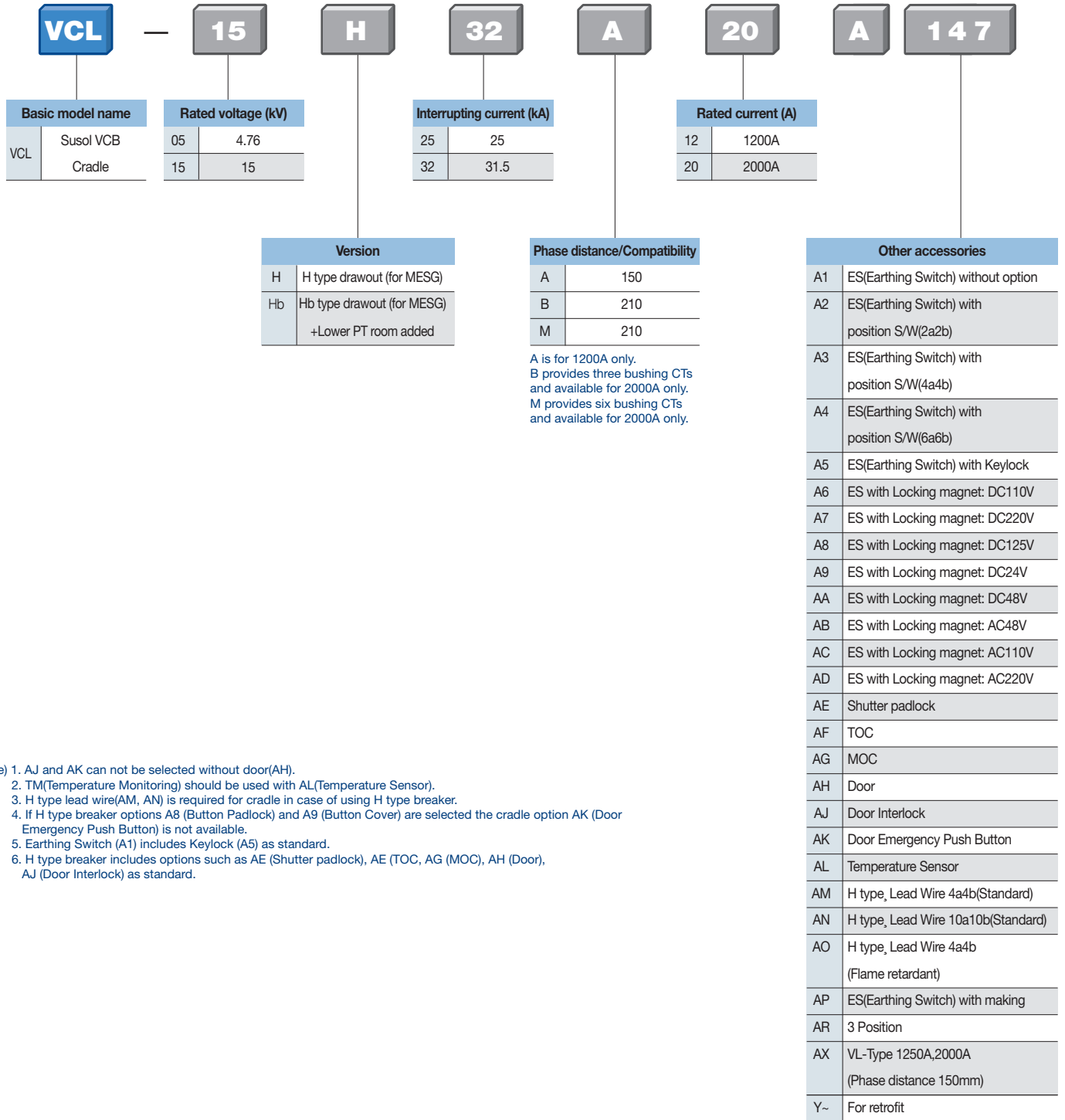

- Note) 1. AJ and AK can not be selected without door(AH).
 2. TM(Temperature Monitoring) should be used with AL(Temperature Sensor).
 3. H type lead wire(AM, AN) is required for cradle in case of using H type breaker.
 4. If H type breaker options A8 (Button Padlock) and A9 (Button Cover) are selected the cradle option AK (Door Emergency Push Button) is not available.
 5. Earthing Switch (A1) includes Keylock (A5) as standard.
 6. H type breaker includes options such as AE (Shutter padlock), AE (TOC, AG (MOC), AH (Door), AJ (Door Interlock) as standard.

Vacuum Circuit Breakers

Susol VCB Series

27kV 25kA 1200/2000A

VH-27



Item		VH-27□25□12	VH-27□25□20
Rated voltage	Ur (kV)	27	
Rated short-circuit current	Isc (kA)	25	
Rated normal current	Ir (A)	1200	2000
Rated withstand voltage	Power frequency (1 min)	Ud (kV)	
	Impulse (1.2×50μs)	Up (kV)	
Rated frequency	fr (Hz)	60	
Rated short-circuit making current	Ip (kA)	65	
Rated short-time withstand current	Ik/tk (kA/s)	25/2	
Rated breaking time	(cycle)	3	
Rated operating sequence		O-0.3s-CO-3min-CO	
Control voltage	Closing coil	(V)	
	Trip coil	(V)	
Auxiliary contacts	Point of contactor	4a4b, 10a10b	
	Class	Class 1	
Trip coil resistance	(Ω)	37±10%	
Closing coil resistance	(Ω)	37±10%	
Rated short-circuit breaking capacity	(MVA)	1169	
Rated opening time	(sec)	≤ 40	
No-load closing time	(sec)	≤ 60	
VI stroke	(mm)	17~18	
Weight	Breaker	(kg)	
	Cradle	(kg)	

* Lifetime with maintenance.

** H type is a box type cradle with CB compartment style structure.

Numbering system

27kV 25kA 1200/2000A

Breaker

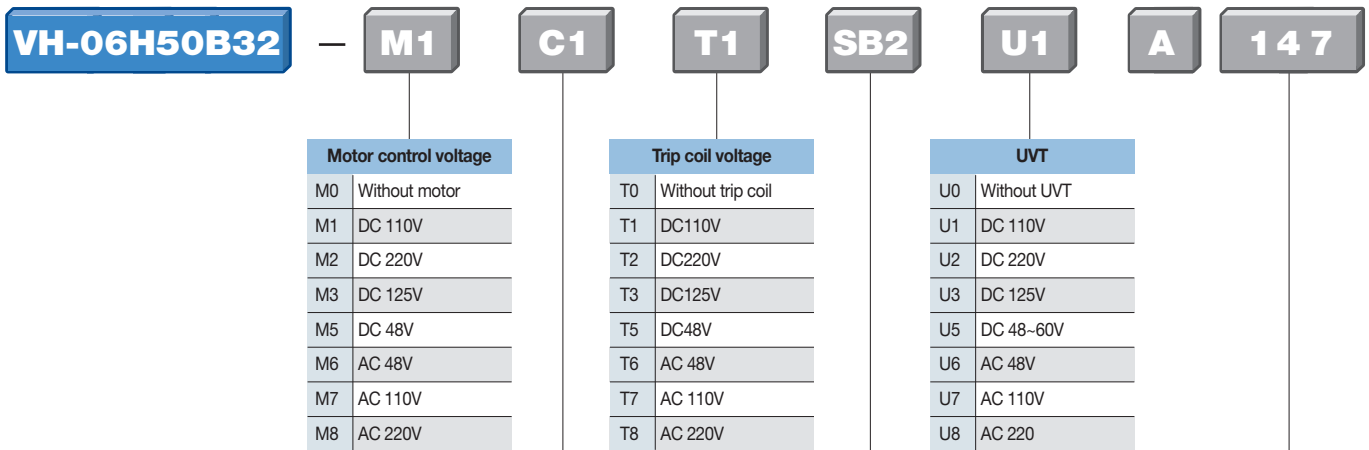
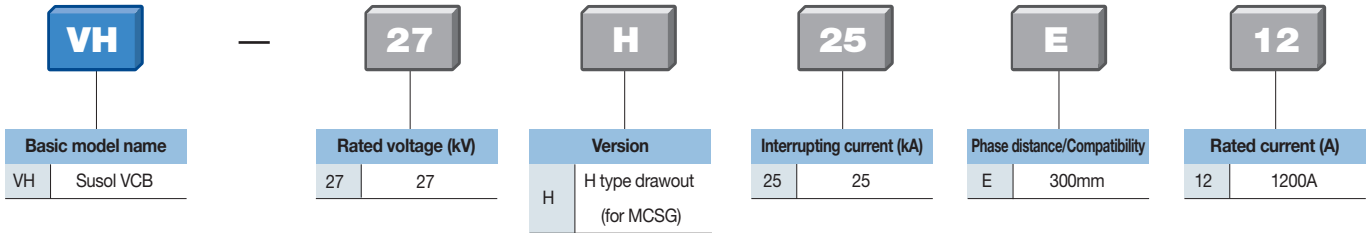

Closing coil voltage	
C0	Without closing coil
C1	DC 110V
C2	DC 220V
C3	DC 125V
C5	DC 48V
C6	AC 48V
C7	AC 110V
C8	AC 220V

Connector and wire		
SB2	Standard	B type connector, 4a4b
		B type connector, 10a10b
SB6	Flame retardant	B type connector, 4a4b

Other accessories ^{Note)}	
A1	Secondary Trip coil
A4	Position s/w(2a2a)
A5	Position s/w(2a2b)
A6	Latch checking s/w
A7	Keylock
A8	Button Padlock
A9	Button cover
AA	Lead Wire
AB	User Plug(Part)
AC	Plug Interlock
AD	Padlock(H type Door Interlock)
AE	MOC
AF	Locking Magnet
AG	ANSI type Charge interlock
AP	Trip Coil Monitoring Contact

Note)

- If A2 (UVT), A4 (Position S/W 2a2a) and A7 (Keylock) are selected, A247 is the type name in the ordering.
- A1 (Secondary Trip Coil) and A2 (UVT) can not be selected simultaneously.
- A4 (Position S/W 2a2a) and A5 (Position S/W 2a2b) can not be selected simultaneously.
- A8 (Button Padlock) and A9 (Button Cover) can not be selected simultaneously.
- AC (Plug interlock),AD (H type Door interlock), AE (MOC) and AF (Locking magnet) are available only for H type.
- In case of B-type connector the flame retardant wire is applicable to auxiliary contacts 4a4b, not to 10a10b.
- Locking magnet can be applied only to H type VCB - breaker and cradle.
- Locking magnet of H type breaker use the same control power supply as motor.
- A-type connector is applicable to P/E/F/G type and B-type connector to H type.
- In case of selecting UVT A6 (Latch checking S/W) is not allowed. A6 (Latch checking S/W) is installed by default to make electrical interlock with UVT.
- Lead wire is enclosed in the breaker in case of ordering fixed type or H type breaker without cradle, installed of cradle in case of ordering the breaker with cradle. If user plug is selected it will be enclosed in the breaker.

Note) A is written only once in case of more than one.

Vacuum Circuit Breakers

Numbering system

27kV 25kA 1200/2000A

Cradle

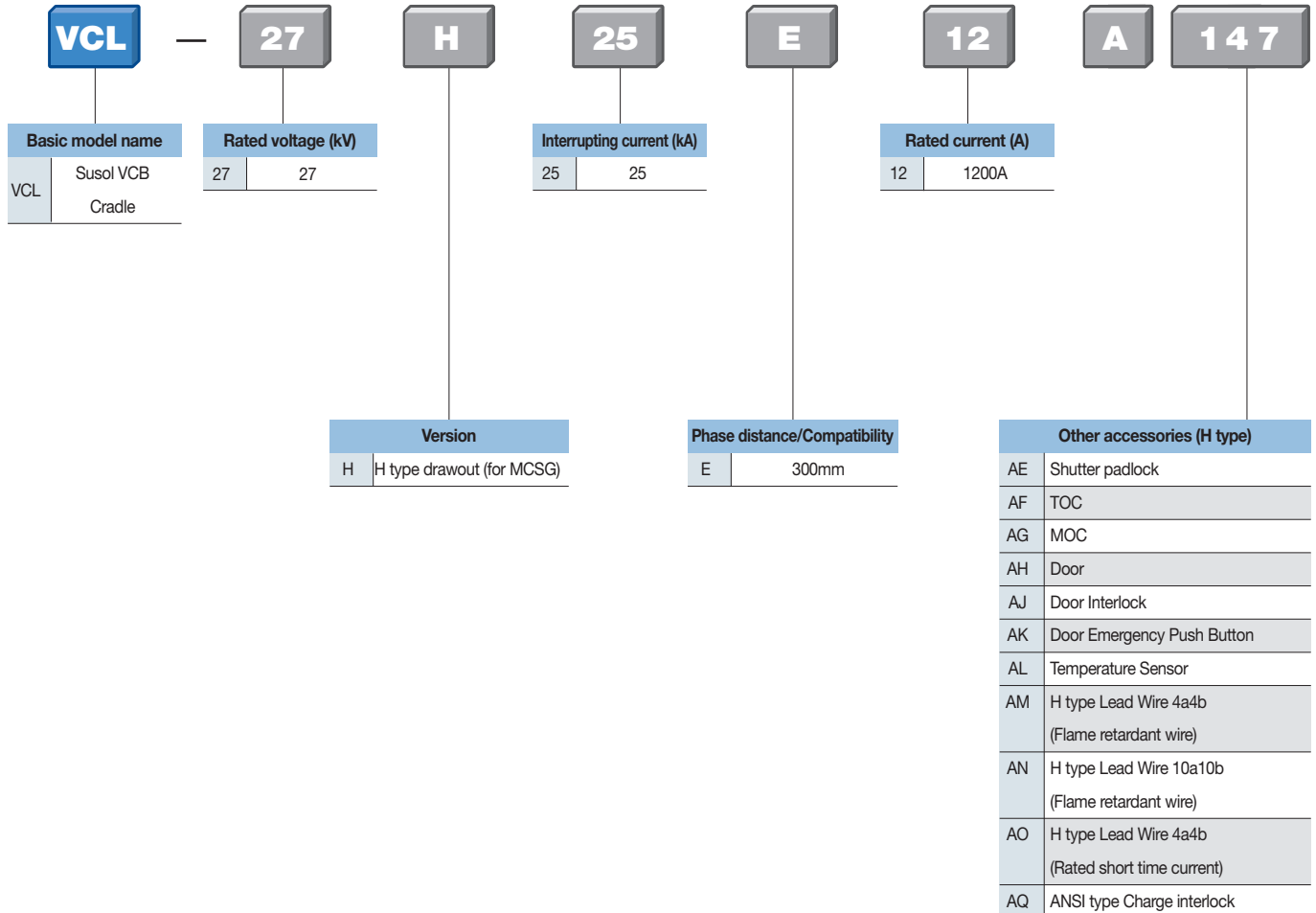

- Note) 1. These accessories for cradle and TM can be applied only to H type.
 2. AJ and AK can not be selected without door (AH).
 3. TM (Temperature Monitoring) should be used with AL (Temperature Sensor).
 4. H type lead wire - one of AM, AN or AO is required for cradle in case of H type breaker.

Note) A is written only once in case of more than one.

Vacuum Circuit Breakers

Susol VCB Series

4.76/15kV 40/50kA 1250/2000/3150A

VH-05/15



Item			VH-05H50C12/20/30			VH-15H40,50C12/20/30		
Rated voltage	Ur (kV)		4.76			15		
Rated normal current	Ir (A)		1250	2000	3150	1250	2000	3150
Rated frequency	fr (Hz)		50/60					
Rated short-circuit current	Isc (kA)		50			40, 50		
Rated short-time withstand current	Ik/tk (kA/s)		50/2			40/2, 50/2		
Rated short-circuit breaking capacity	(MVA)		412			1039, 1299		
Rated short-circuit making current	Ip (kA)		2.5 × Isc (50Hz)/2.6 × Isc (60Hz)					
Rated breaking time	(Cycle)		3					
Rated withstand voltage	Power frequency (1 min)	Ud (kV)	19			36		
	Impulse (1.2 × 50μs)	Up (kV)	60			95		
Rated operating sequence			O-0.3s-CO-3min-CO					
Control voltage	Closing coil	(V)	DC 125V					
	Trip coil	(V)	DC 125V					
Auxiliary contacts *			3a3b					
Rated opening time	(sec)		≤ 0.04					
No-load closing time	(sec)		≤ 0.06					
Lifetime	Mechanical		10,000					
	Electrical		See graph					
Installation version	Drawout		H type (for MESG)					
Phase distance	(mm)		254					
Weight	Breaker (MESG, MCSG)	(kg)	230	230	265	230	230	265
	Cradle (MESG, MCSG)	(kg)	248	248	286	248	248	286
Applicable standard			ANSI/IEEE Std. C37.09, KEPIC EED 1100					

* Two(2) "Early b" auxiliary contact is provided.

Vacuum Circuit Breakers

Numbering system

4.76/15kV 40/50kA 1250/2000/3150A

Breaker

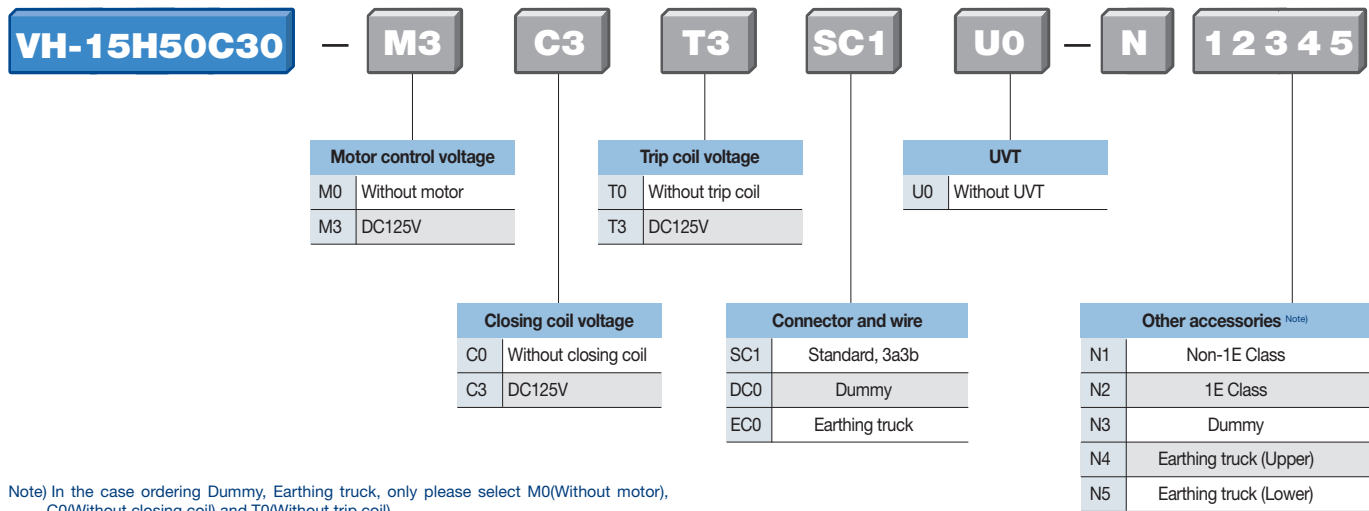
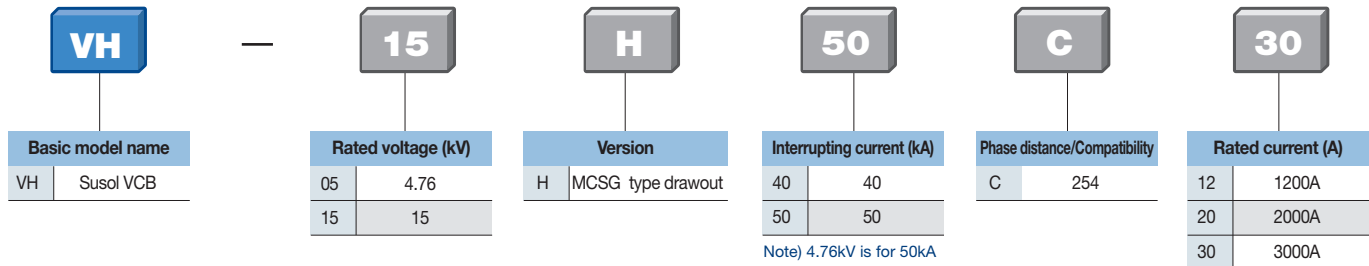

Cradle

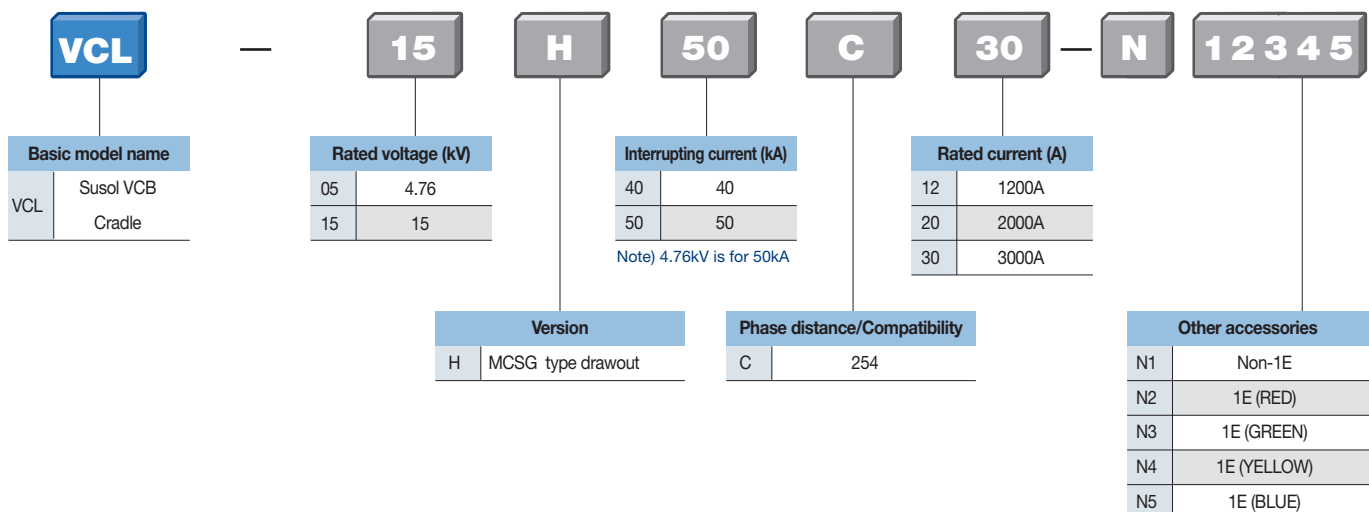



Safety Instructions

- For your safety, please read user's manual thoroughly before operating.
- Contact the nearest authorized service facility for examination, repair, or adjustment.
- Please contact qualified service technician when you need maintenance. Do not disassemble or repair by yourself!
- Any maintenance and inspection shall be performed by the personnel having expertise concerned.



© 2013.3 LSIS Co.,Ltd. All rights reserved.

www.lsis.com

■ **LSIS USA Inc. Chicago Branch**

2000 Millbrook Drive Lincolnshire, IL 60069

Tel: 847-941-8240~59 sales.us@lsis.com Fax: 847-941-8259

■ **HEAD OFFICE**

LS-ro 127 (Hogye-dong) Dongan-gu, Anyang-si,
Gyeonggi-Do Korea

Tel. 82-2-2034-4902, 4684, 4429 Fax. 82-2-2034-4555

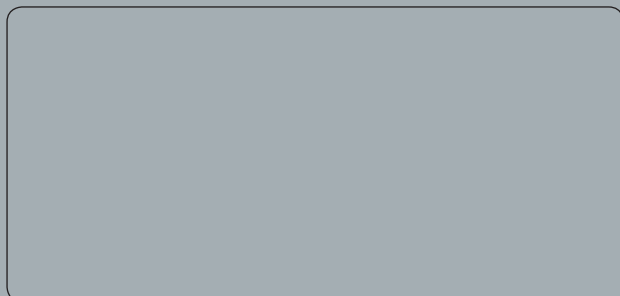

Specifications in this catalog are subject to change without notice due to continuous product development and improvement.

■ **Global Network**

Overseas Subsidiaries

• **LSIS USA Inc. >> Chicago, America**

2000 Millbrook Drive, Lincolnshire, Chicago, IL 60069, United States of America
Tel: 1-847-941-8240 / Fax: 1-847-941-8259 / E-mail: seungheonc@lsis.com

• **LSIS (Middle East) FZE >> Dubai, U.A.E**

LOB 19-205, JAFZA View Tower, Jebel Ali Free Zone, Dubai, United Arab Emirates
Tel: 971-4-886-5360 / Fax: 971-4-886-5361 / E-mail: hschoib@lsis.com

• **LSIS Europe B.V. >> Schiphol-Rijk, Netherlands**

1st Floor, Tupoleviaan 48, 1119NZ, Schiphol-Rijk, The Netherlands
Tel: 31-20-654-1420 / Fax: 31-20-654-1429 / E-mail: junshickp@lsis.com

• **LSIS Japan Co.,Ltd >> Tokyo, Japan**

Tokyo Club Building 13F, 2-6, Kasumigaseki 3-chome, Chiyoda-ku, Tokyo, 100-0013
Tel: 81-3-6268-8241 / Fax: 81-3-6268-8240 / E-mail: jschuna@lsis.com

• **LSIS Dalian Co.,Ltd. >> Dalian, China**

No. 15, Liaohexi 3-Road, Economic and Technical Development Zone, Dalian 116600, China
Tel: 86-411-8273-7777 / Fax: 86-411-8730-7560 / E-mail: tangyh@lsis.com

• **LSIS Wuxi Co.,Ltd. >> WUXI, China**

102-A, National High & New Tech Industrial Development Area, Wuxi, Jiangsu, 214028, P.R.China
Tel: 86-510-8534-6666 / Fax: 86-510-522-4078 / E-mail: wangzy@lsis.com

• **LS-VINA Industrial Systems Co.,Ltd. >> Hanoi, Vietnam**

Nguyen Khe, Dong Anh, Hanoi, Vietnam
Tel: 84-4-6275-8055 / Fax: 84-4-3882-0220 / E-mail: sjbaik@lsis.com

Overseas Branches

• **LSIS Co.,Ltd. Rep.Office, Vietnam**

Gema Dept Tower 18F, 6 Le Thanh Ton, District 1, HCM, Vietnam
Tel: 84-8-3823-7890 / E-mail: hwyim@lsis.com

• **LSIS Moscow Office, Russia**

123610, Krasnopresnenskaya, nab, 12, building 1, office No.1005, Moscow, Russia
Tel: 7-495-258-1466, 1467 / Fax: 7-495-258-1466, 1467 / E-mail: jdpark1@lsis.com