

# NEMA – QUICK REFERENCE CHART

Keyseat Dimensions	NEMA Shaft (U)	Key (R)	Dimen (S)
	3/8	21/64	Flat
	1/2	29/64	Flat
	5/8	33/64	3/16
	7/8	49/64	3/16
	1-1/8	63/64	1/4
	1-3/8	1-13/64	5/16
	1-5/8	1-13/32	3/8
	1-7/8	1-19/32	1/2
	2-1/8	1-27/32	1/2
	2-3/8	2-1/64	5/8
	2-1/2	2-3/16	5/8
	2-7/8	2-29/64	3/4
	3-3/8	2-7/8	7/8
3-7/8	3-5/16	1	

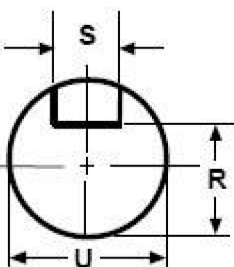
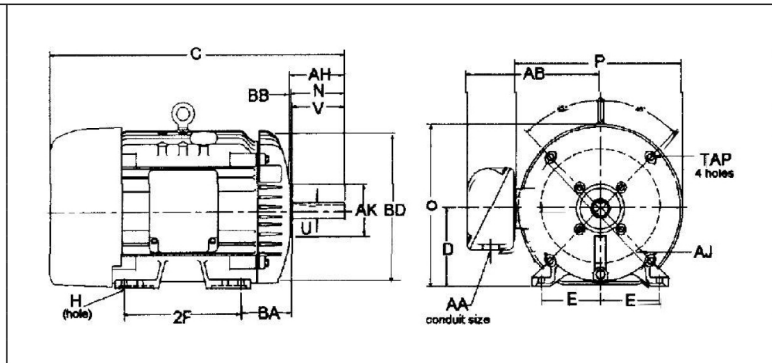

\* Indicates the number is an approximate value. These dimensions are specific to each manufacturer.

FRAME	D	E	2F	H	N*	O*	P*	U	V	AA	AB*	AH	AJ	AK	BA	BB	BD*	TAP
42	2-5/8	1-3/4	1-11/16	9/32 SLOT	1-1/2	5	4-11/16	3/8	1-1/8	3/8	4-1/32	1-5/16	3-3/4	3	2-1/16	1/8	4-5/8	1/4-20
48	3	2-1/8	2-3/4	11/32 SLOT	1-7/8	5-7/8	5-11/16	1/2	1-1/2	1/2	4-3/8	1-11/16	3-3/4	3	2-1/2	1/8	5-5/8	1/4-20
56 56H	3-1/2	2-7/16	3 5	11/32 SLOT	2-7/16 2-1/8	6-7/8	6-5/8	5/8	1-7/8	1/2	5	2-1/16	5-7/8	4-1/2	2-3/4	1/8	6-1/2	3/8-16
143T 145T	3-1/2	2-3/4	4 5	11/32	2-1/2	6-7/8	6-5/8	7/8	2-1/4	3/4	5-1/4	2-1/8	5-7/8	4-1/2	2-1/4	1/8	6-1/2	3/8-16
182 184 182T 184T	4-1/2	3-3/4	4-1/2 5-1/2 4-1/2 5-1/2	13/32	2-11/16 2-11/16 3-9/16 3-9/16	8-11/16	7-7/8	7/8 7/8 1-1/8 1-1/8	2-1/4 2-1/4 2-3/4 2-3/4	3-1/4	5-7/8	2-1/8 2-1/8 2-5/8 2-5/8	5-7/8 5-7/8 7-1/4 7-1/4	4-1/2 4-1/4 8-1/2 8-1/2	2-3/4	1/8 1/8 1-1/4 1-1/4	6-1/2 6-1/2 9 9	3/8-16 3/8-16 1/2-13 1/2-13
213 215 213T 215T	5-1/4	4-1/4	5-1/2 7 5-1/2 7	13/32	3-1/2 3-1/2 3-7/8 3-7/8	10-1/4	9-9/16	1-1/8 1-3/8 1-3/8	3 3-3/8 3-3/8	3/4	7-3/8	2-3/4 2-3/4 3-1/8 3-1/8	7-1/4	8-1/2	3-1/2	1/4	9	1/2-13
254U 256U 254T 256T	6-1/4	5	8-1/4 10 8-1/4 10	17/32	4-1/16 4-1/16 4-5/16 4-5/16	12-7/8	12-15/16	1-3/8 1-3/8 1-5/8 1-5/8	3-3/4 3-3/4 4 4	1	9-5/8	3-1/2 3-1/2 3-1/4 3-1/4	7-1/4	8-1/2	4-1/4	1/4	10	1/2-13
284U 286U 284T 286T 284TS 286TS	7	5-1/2	9-1/2 11 9-1/2 11 9-1/2 11	17/32	5-1/8 5-1/8 4-7/8 4-7/8 3-3/8 3-3/8	14-5/8	14-5/8	1-5/8 1-5/8 1-7/8 1-7/8 1-5/8 1-5/8	4-7/8 4-7/8 4-5/8 4-5/8 3-1/4 3-1/4	1-1/2	13-1/8	4-5/8 4-5/8 4-3/8 4-3/8 3 3	9	10-1/2	4-3/4	1/4	11-1/4	1/2-13
324U 326U 324T 326T 324TS 326TS	8	6-1/4	10-1/2 12 10-1/2 12 10-1/2 12	21/32	5-7/8 5-7/8 5-1/2 5-1/2 3-15/16 3-15/16	16-1/2	16-1/2	1-7/8 1-7/8 2-1/8 2-1/8 2-1/8 2-1/8	5-5/8 5-5/8 5-1/4 5-1/4 5-1/4 5-1/4	2	14-1/8	5-3/8 5-3/8 5 5 5 5	11	12-1/2	5-1/4	1/4	13-3/8	5/8-11
364U 365U 364T 365T 364TS 365TS	9	7	11-1/4 12-1/4 11-1/4 12-1/4 11-1/4 12-1/4	21/32	6-3/4 6-3/4 6-1/4 6-1/4 4 4	18-1/2	18-1/4	2-1/8 2-1/8 2-3/8 2-3/8 1-7/8 1-7/8	6-3/8 6-3/8 5-7/8 5-7/8 3-3/4 3-3/4	2-1/2	15-1/16	6-1/6 6-1/6 5-5/8 5-5/8 3-1/2 3-1/2	11	12-1/2	5-7/8	1/4	13-3/8	5/8-11
404U 405U 404T 405T 404TS 405TS	10	8	12-1/4 13-3/4 12-1/4 13-3/4 12-1/4 13-3/4	13/16	7-3/16 7-3/16 7-5/16 7-5/16 4-1/2 4-1/2	20-5/16	20-1/8	2-3/8 2-3/8 2-7/8 2-7/8 2-1/8 2-1/8	7-1/8 7-1/8 7-1/4 7-1/4 4-1/4 4-1/4	3	18	6-7/8 6-7/8 7 7 4 4	11	12-1/2	6-5/8	1/4	13-7/8	5/8-11
444U 445U 444T 445T 447T 449T 444TS 445TS 447TS 449TS	11	9	14-1/2 16-1/2 14-1/2 16-1/2 20 25 14-1/2 16-1/2 20 25	13/16	8-5/8 8-5/8 8-1/2 8-1/2 8-15/16 8-15/16 5-3/16 5-3/16 4-15/16 4-15/16	22-7/8	22-3/8	2-7/8 2-7/8 3-3/8 3-3/8 3-3/8 3-3/8 2-3/8 2-3/8 2-3/8 2-3/8	8-5/8 8-5/8 8-1/2 8-1/2 8-1/2 8-1/2 4-3/4 4-3/4 4-3/4 4-3/4	3	19-9/16 19-9/16 19-9/16 19-9/16 21-11/16 21-11/16 19-9/16 19-9/16 21-11/16 21-11/16	8-3/8 8-3/8 8-1/4 8-1/4 8-1/4 8-1/4 4-1/2 4-1/2 4-1/2 4-1/2	14	16	7-1/2	1/4	16-3/4	5/8-11